

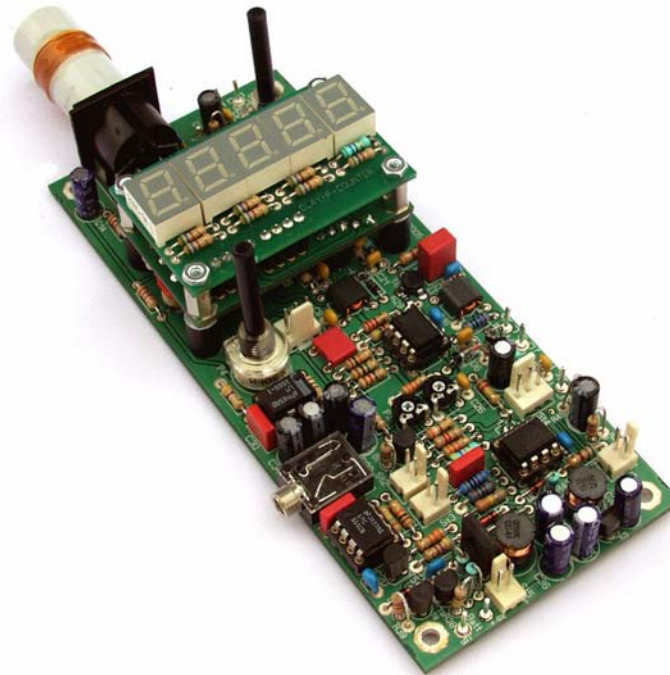

**DL-QRP-AG**



## DipIt, the ultimate Dipmeter

Manual Vers. 1.21

November 22.2007

© QRPproject Molchstr. 15 12524 Berlin <http://www.QRPproject.de> fone: +49(30) 85 96 13 23 e-mail: [support@QRPproject.de](mailto:support@QRPproject.de)  
Manual: **Flservice** Peter Zenker DL2FI email: [dl2fi@qrpproject.de](mailto:dl2fi@qrpproject.de)

## „DipIt“, the Super- Dipmeter“ of German QRP Club DL- QRP- AG

Design: Peter Solf, DK1HE

Project Coordination: Peter Zenker, DL2FI

Kit Realisation: Nikolai Zenker, DL7NIK

Manual-Translation: Pete Meier, WK8S and Peter Zenker, DL2FI

### Preface:

Very often a home brewing radio amateur comes into the embarrassment to measure the unknown resonant frequency of a receiver or transmitter oscillating circuit or to adjust a post Mixer filter to the correct frequency. Such or similar measurement tasks can be done easily with a so called "dipper". The "old rabbits" beyond us know, this instrument used to be the basic equipment of their amateur activity and often it was the only RF measuring tool available when they constructed their noteworthy projects. But using a dipper was almost forgotten in the course of the commercialization of amateur Radio for times. Now, when homebrewing in HAM Radio has a renaissance, the dipper is more up-to-date than ever. It can help to do lots of sophisticated measurements during homebrewing of Radio Kits at low cost rates and it can eliminate the need to buy much more expensive test equipment if it is well designed. On multiple request of DLQRP AG Club members the author developed a "Superdipper kit" which is equipped with some extra practical additional functions apart from the real basic functions.

### Technical data:

- frequency range: 1-42 MHz (divided up into 5 areas by means of plug in coils) VHF / UHF Option with plug in Oscillator
- new highly sensitive "sweep-frequency method"
- frequency indication by 5-digit LED display
- resonance display with a super bright light-emitting diode
- frequency tuning by 10- turn potentiometer
- heterodyne frequency meter with an additional headphone output +BNC input (with attenuator)
- absorption frequency measurement with optical display (LED)
- amplitude stable +7 dBm generator output for peripheral attachments (Antenna analyzer and other)
- integrated switching transformer working with 4 AA batteries
- visual battery voltage control

### Basics:

The mode of action of classic dip metres is based on the fact that the amplitude of an L/C oscillator decreases if it is coupled to a resonant circuit working at the same frequency (the dip). If the oscillator is variable and provided with a calibrated frequency scale, then it can be used easily

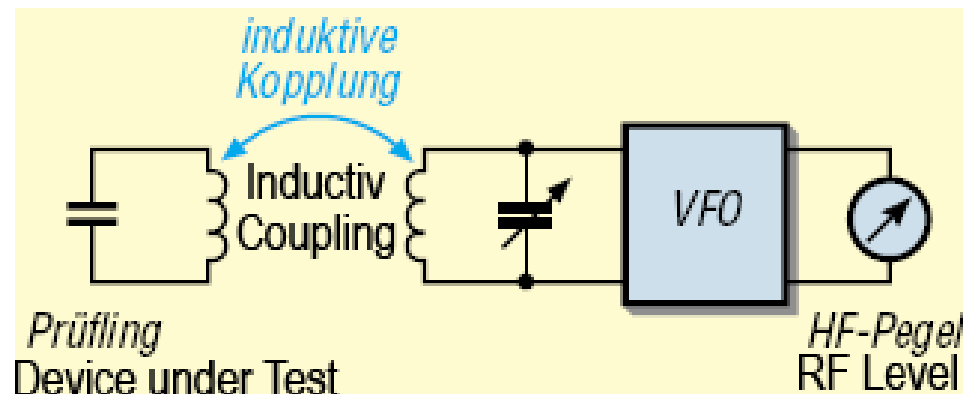

to find the resonant frequency of an unknown L/C Circuit. To have a broader frequency range and good resolution at the same time, most Dip Metres use Plug in coils.

To find the resonant frequency of an unknown circuit, the Dipmetre Coil usually will be coupled inductive or capacitive to the object to be measured. The actual amplitude of the VFO (or the proportional Grid current if it is a tube Dipper, normally can be controlled by using an analog Voltmeter.

All previous dipmeter more or less in common show the following weak points

The amplitude of the oscillator changes from the beginning to the end of the tuning range. It strongly depends on the chosen frequency range. All models have a sensitivity control, which permanent must be regulated to keep the instrument at 2/3 of full scale where eventually a dip could be seen at its best. At higher frequency it often is impossible to adjust the instrument to 2/3 of full scale.

To achieve good accuracy and avoid detuning of the measured object, the Dip Meter's coil always should be coupled as loose as possible. At the recommended loose coupling however, sensitivity of a normal Dipmeter decreases rapidly. Often the "Dip" more or less only can be suspected then it can be seen.

The "super dip metre" developed by the author avoids problems mentioned above with the following trick :

The heart of the circuit is a varactor controlled VFO. The tuning range is approximately an octave. The normal Tuning Voltage for the Varactor becomes superimposedly with a balanced sawtooth voltage of small amplitude. The result is a balanced frequency modulation (sweeping) of the VFO around the carrier mid frequency. The chosen frequency shift is approximately +/- 0.2% of the current oscillator frequency. The sweep rate is approx. 400 Hz. The VFO frequency if coupled to an object in resonance "sweeps" over the resonating curve of the examinee now.

## DK1HE - " Superdipper " Diplt

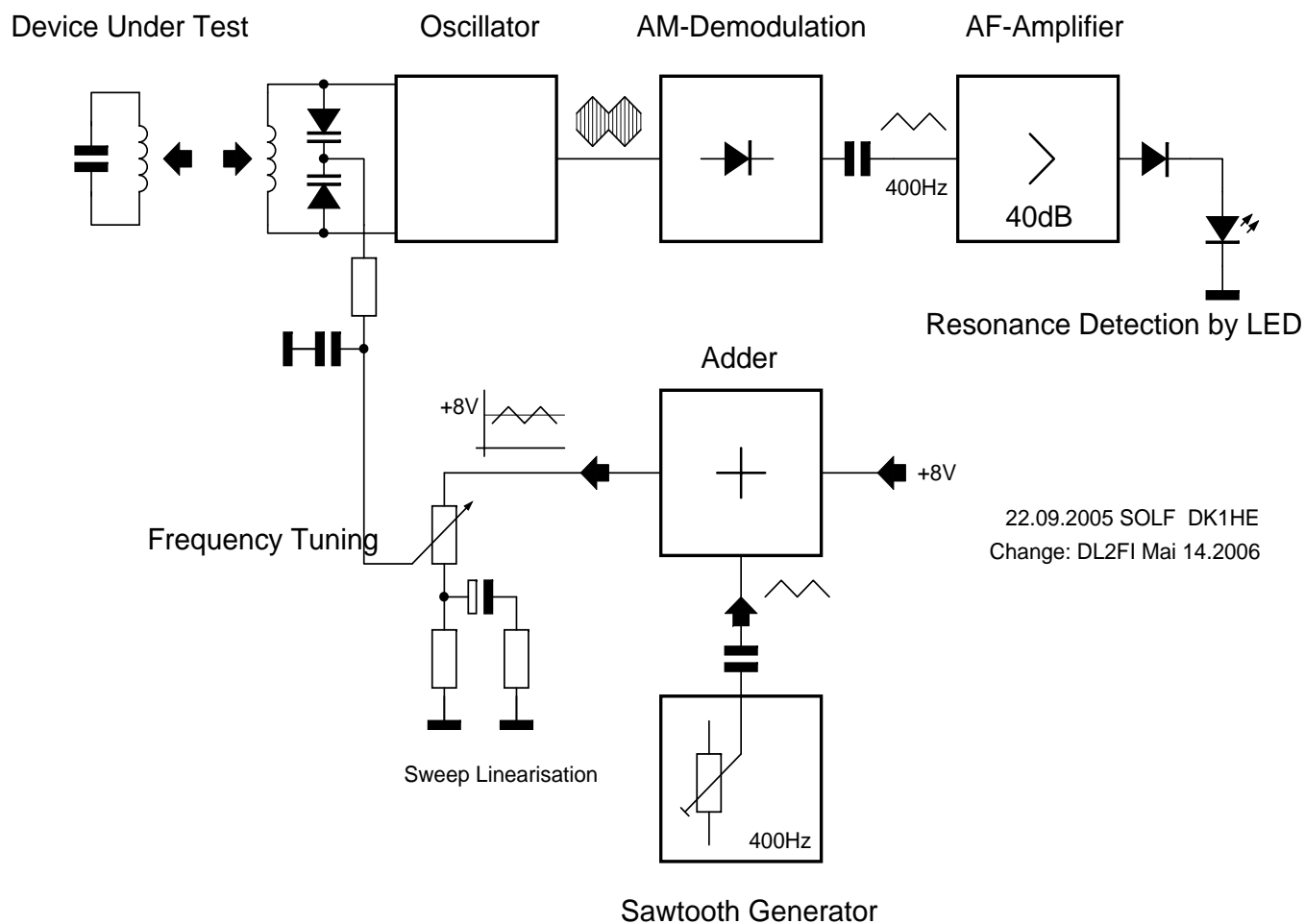

The same is carried out manually by the operator at conventional dip metres with the tuning knob but much slower !!

The answer of the VFO is a 400 Hz amplitude modulation of its HF output voltage due to fact, that the examinee sucks more or less energie from the VFO depending on the frequency being more or less in resonance or not. The modulation depth is deeper, the more exact the oscillator mid frequency agrees with the resonance maximum of the examinee or the more strongly the coupling is carried out. A demodulator circuit stage with a capacitive coupling separates the 400 Hz AC signal. The Super Dippers display consists of a simple AF Amplifier which amplifies the 400 Hz signal by about 40 dB supplies nad a LED which lightens up proportional to the signal strength after rectification. Amplitude changes can be recognized very cleanly since the light-emitting diode is fed with 400 Hz half waves. Alternativ of course a needle meter can be used if wanted.

In the measurement procedure described above the absolute HF level of the oscillator plays a subordinate role (only the modulation contents are judged). A Potentiometer for the adjusting of the sensitivity can therefore be dropped.

Since one can almost arbitrarily amplify the demodulated 400 Hz signal as high as you want, this new has Dipmeter design offers a significantly higher sensitivity than all previous equipment. The coupling to the examining object can be carried out extremely loose what is of benefit to a high reading accuracy. ( PA coils still can be dipped cleanly from a distance of > 20 cm giving a chance to measure them without any detuning.

### Wiring description of the individual circuit stages:

#### 1. VFO:

A Hartley oscillator built up with JFet T1 forms the heart of the circuit. The oscillator circuit consists of the L1 and tuning diodes D1-D2. By means of the 10 turn Pot P5 the oscillator frequency can be varied around by about an octave. By choice of the plug in coil a total frequency range of approx. 1 MHz to 42 MHz is covered in 5 steps. D3 has two functions: 1. it serves for the automatic bias voltage generation of T1 and d2. it works as AM demodulator. R2-C2 form a AF lowpass filter with a cutoff frequency of about 4 kHz. The demodulated 400 Hz AF Signal, which already has been preamplified by T1 is coupled to

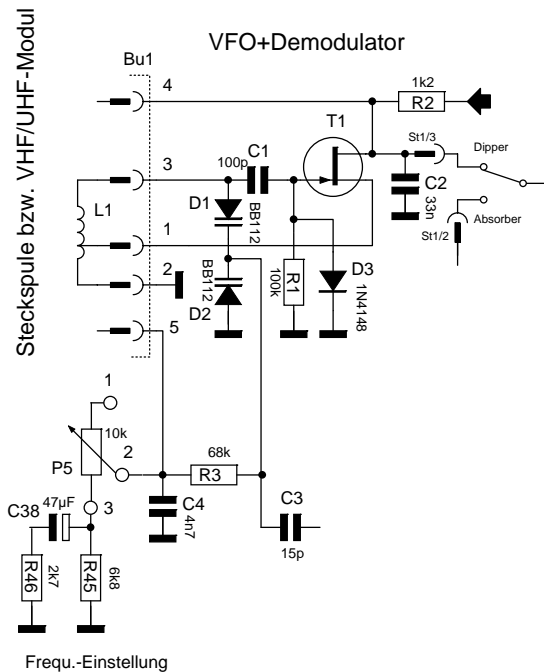

the induction amplifier by C2 / S1.

#### 2. Frequency sweep generator:

The timer circuit IC3 forms an R/C oscillator with a balanced sawtooth output voltage. The generated frequency is approximately 400 Hz. The output signal is divided by R19/R20 the an optimal value for the frequency swp operation. IC2a works as adding stage. The sawtooth voltage coupled by C17 is added to the stabilized DC coupled by R18. At the output of the OpAmp now we have an 8V DC with a balancedly superimposed sawtooth.

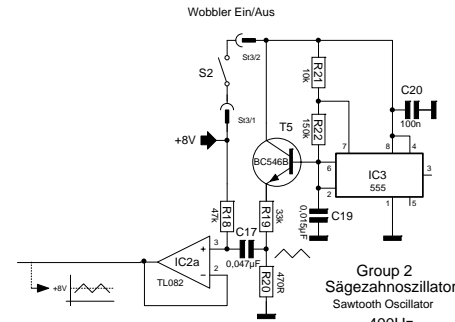

This is feed into tuning Pot P5. R45 defines the VFO-tuning range. C38-R46 and P5 form a voltage divider for the sawtooth quota of the tuning voltage. They also linearize the unlinear Voltage/Capacity curve of

the diodes D1/D2 especially in the lower voltage range. By this methode an almost constant sweep shift is obtained over the complete variation area.

#### 3. Indication amplifier:

The demodulated 400 Hz signal coming from T1 via selector switch S1 reaches the input of the AF amplifier IC1a. By means of R12-R13 the gain is set to 40 dB. Capacitor C15 serves to isolate the DC quota of the signal voltage. Byt P2 the DC quiescent output level of the OPs is adjusted so that the light-emitting diode D12 (resonance display) just starts "week glowing" without AC signal. The circuit works in addition as a rectifier at this operating

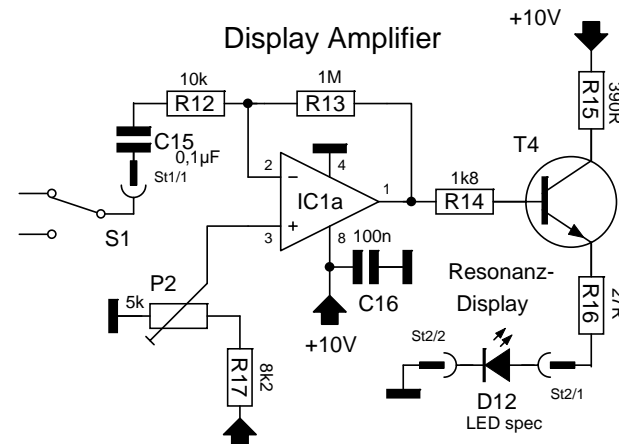

as a rectifier at this operating

point adjustment. At an available AC signal the positive half waves of the OP output voltage cause a periodical current flow in the light-emitting diode. The brightness is proportional to the signal amplitude. T4 serves for the current load reduction of IC1a. R15 limits the diode current to about 20 mA.

#### 4. VFO buffer stage, Power Amplifier, Regulation Circuit Stage

Capacitor C3 couples the low harmonic VFO signal directly to the following JFET buffer stage T2. The RF Voltage at the low-impedance source is feed into the frequency counter module via connector Bu3 to to display the actual VFO frequency. It serves furthermore than as Local Oscillator (LO) signal for the beat frequency measurement. Impedance transformation is carried out by TR1 to the following output amplifier T6. By means of the counter-coupling resistance

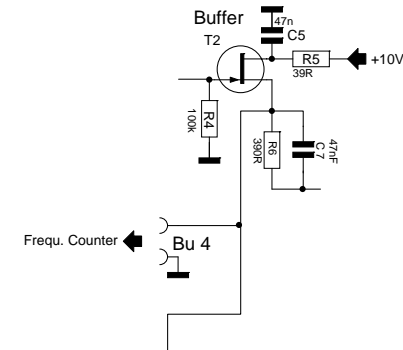

of the counter-coupling resistance

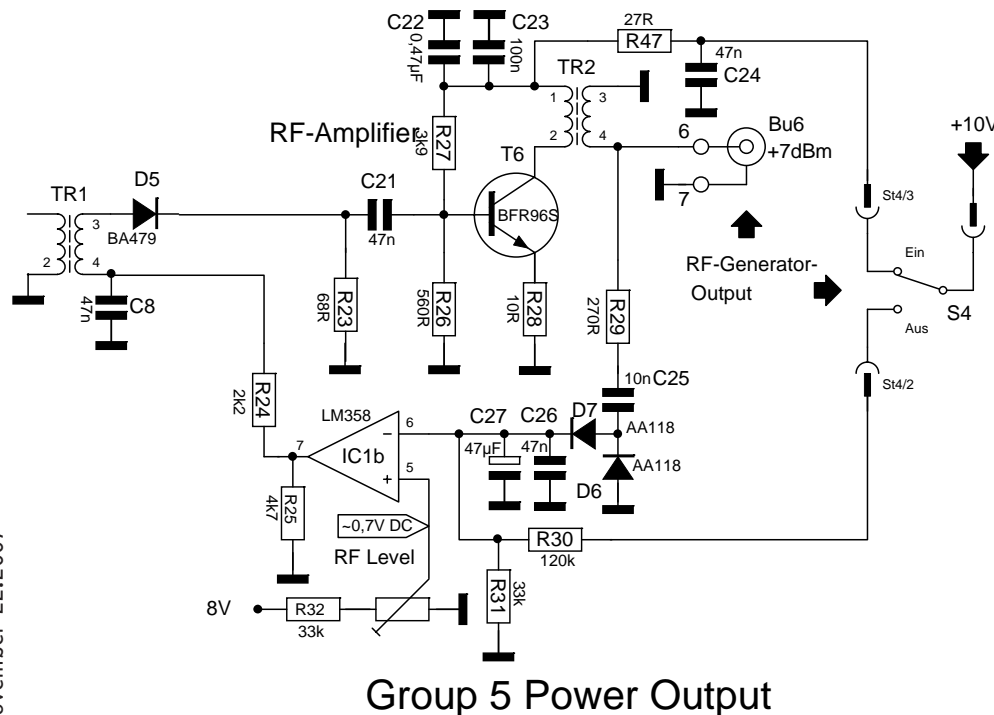

Group 5 Power Output

R28 the stage gain is adjusted to 20 dB. The transformer TR2 transforms the dynamic Collector-Resistance of T6 to the system impedance of 50 ohms. The amplified RF signal can be taken from the signal source output jack Bu6 for individual applications.

To ensured a frequency range and frequency independent output level of 7dBm the circuit around Transistor around T6 is designed as a "VCA" (Voltage controlled amplifier). The actual RF output voltage at Bu6 is supplied about the decoupling resistor R29 to the peak voltage rectifier circuit D6-D7 and after filtering by means of C26-C27 as nominal "Ebit Voltage" passed to the inverting input of IC1b. The non inverting Input is feed with a "Debit Voltage, controlled by variable Resistor P3. PIN-Diode D5 is the "setting device", together with R23 it forms an RF Voltage divider, controlled by the Diode current.

Example:

if the rectified RF Voltage is smaller then the Level preadjusted by P3, the DC output of IC1b gets more positive. By means of R24 the current in Diode D5 increases. This causes an increase of the dynamic resistance of D5. So the RF Voltage at R23 (Input of RF Amplifier) increases until the rectified output equals th Value predefined by P3. Is the level at Bu6 is too high, the "debit voltage" is higher then the "Ebit voltage". Now the output at IC1b decreases as well as the current in D5. Lower current in D5 causes higher dynamic resistance in D5, so the RF Voltage at T6 also will decrease until the inverting input meets the "Debit Voltage" again.

#### 5. Heterodyne Frequency Measurement:

The "heterodyne frequency measuring instrument" fallen into oblivion long ago is excellently suitable for the frequency measurement of small HF Voltages in the  $\mu\text{V}$  area or to the telemetering of unknown signals over an aerial. Integrated in our SuperDipper you find a direct conversion mixer built up with the MOSFET-Tetrode T3. The signal voltage coming from the input jack Bu5 reaches via adjustable reducer P1 the Gate 1 of the mixer stage. The Lo signal coming from T6 is brought to the Gate 2. The difference frequency relevant for the measuring is at the output of T3 with an assessment frequency range of 4 kHz of (Lowpassfilter R10-C12) at the



## 8. battery voltage control:

To get full control over the batterie status, a visual battery voltage supervision was integrated into the SuperDipper. The Comperator IC2b compares the voltage down shared about R40-R41 (4,4V) with the battery

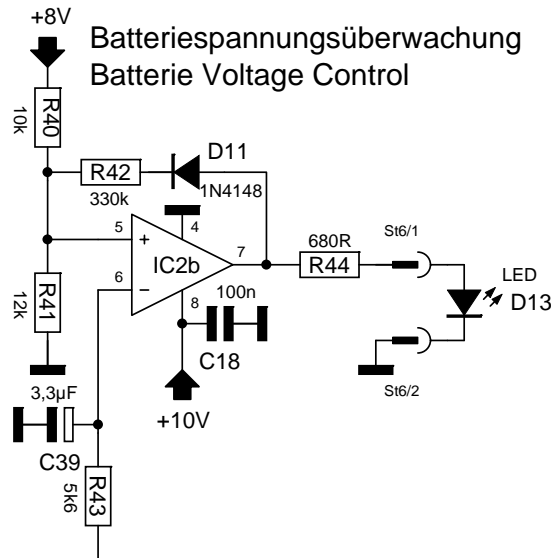

voltage supplied by R43. If the actual Voltage falls below the 4.4 volt threshold, the output from IC2b switches "high" and the approaching end of the battery voltage range signals the light-emitting diode D13.

By means of D11-R42 the Komparator gets a hysteresis what a stable function ensures also at battery Voltage

A following AM demodulation stage separates the the 400 Hz AC tone. The display part of DipIt is a simple 40dB AF Amplifier, a rectifier and a superbright LED.

Using this method, the only criteria of detecting resonant devices is the AM-Modulation so the different Amplitude hight of the VFO depending on its frequency is no longer a problem. That fact, that an AM signal can be amplified very easy increases the sensitivity of the dipper dramatically. Coupling between DipIt and DUT can be much looser then with any conventional dipmeter, the dip is absolutely clearly.

## Beginning of the structure Building group 1, voltage supply

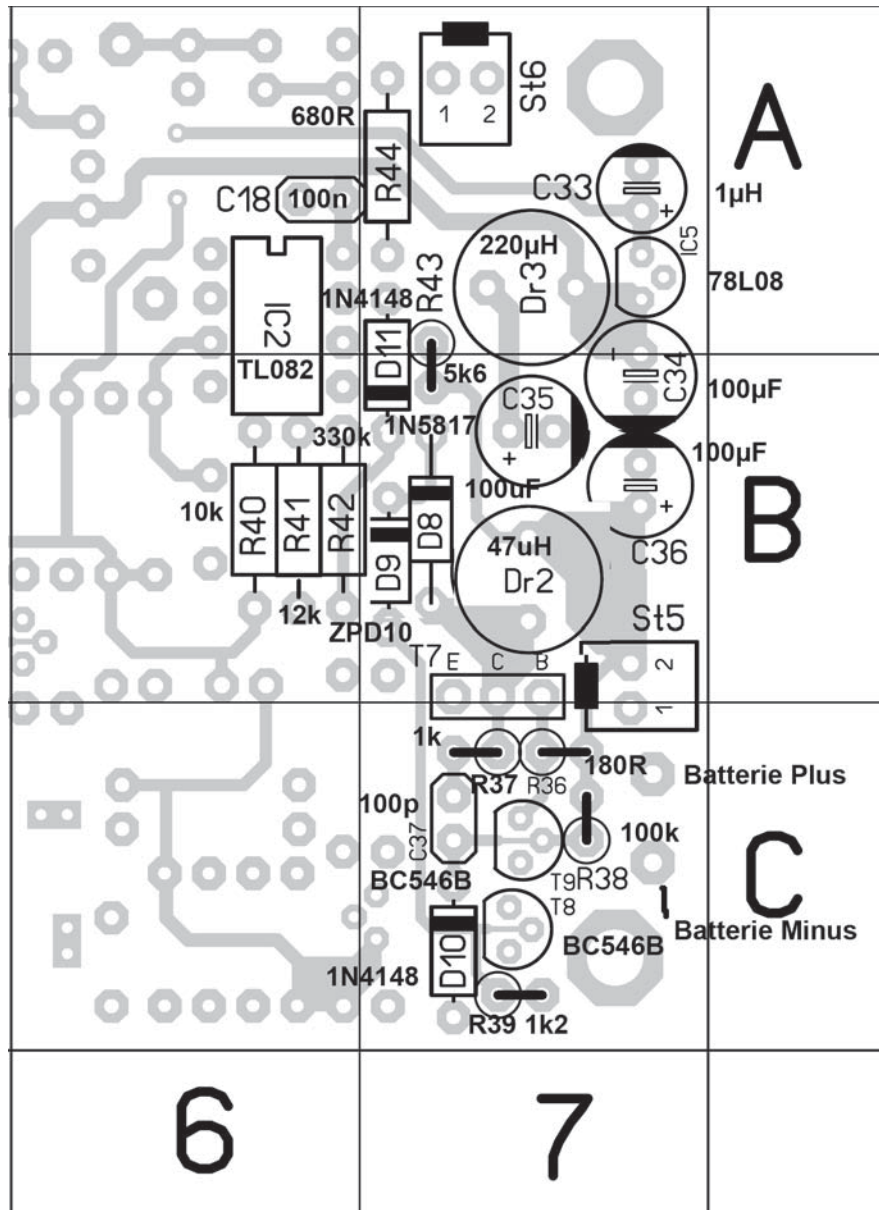

Beginning here, there are ESD sensitive parts used.

[ ] St6 A/7 **CHANGE!!! ST6 do not install!!!**

[ ] R44	A/7	6	680R
[ ] C18	A/6		100nF
[ ] D11	A-B/7		1N4148 pay attention to situation of the ring-stamp (cathode)
[ ] R43	A-B/7		5,6K
[ ] Dr3	A/7		220uH
[ ] Dr2	B/7		47uH
With the following Elko(electrolytic) be careful how they are installed. The longer leg is the positive pole, the housing is marked on the side with the minus connection mark.			
[ ] C35	B/7		100uF rad. Elko
[ ] C33	A/7		1uF rad. Elko
[ ] C34	A-B/7		100uF rad Elko
[ ] C36	B/7		100uF rad Elko
[ ] R40	B/6		10K 1%
[ ] R41	B/6		12K 1%
[ ] R42	B/6-7		330K
[ ] D8	B/7		1N5817
[ ] D9	B/7		ZPD10
[ ] St5	B-C/7		Patch cord receptacle 2-pol, tongue inward!
[ ] R37	C/7		1K
[ ] R36	C/7		180R
[ ] C37	C/7		100pF
[ ] R38	C/7		100K
[ ] D10	C/7		1N4148 pay attention to situation of the tax stamp
[ ] R39	C/7		1,2K
Transistors and ICs are more or less sensitive to ESD. It is however a good exercise with semiconductors to pay attention and adhere to the ESD safety precautions. Use a ESD bracelet or at least touch a bare, grounded surface, before you touch the transistors.			
[ ] T8	C/7		BC546B
[ ] T9	C/7		BC546B
The BD137 is inserted in such a way that the marked side is turned away from the choke/coil and points to the edge of the board.			
[ ] T7	B-C/7		BD135 (oder BD137, BD139)
[ ] IC5	A/7		78L08 T092
Pay attention to the correct installation of IC 2. The notch marks pin 1 (to			

the left of the notch) in the bill of material  
 IC2                      A-B/6 TL082                      DIL8

On the lower surface below the IC2 a tantalum capacitor is soldered. The POSITIVE side is marked by a bar with this design (SMD Baugr. B). The bar is clearly seen towards the diode and towards the outside edge of the pc

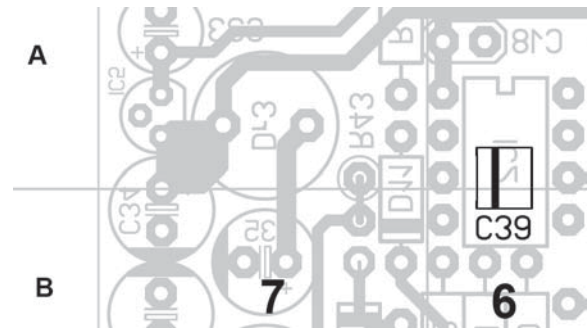

board.  
 C39                      3,3 uF 16V                      Tantalum SMD

Now socket Bu4 is still missing, to which the display is attached later. It is put on the component side and soldered on the solder side. We use 2 female sockets, which we break-out carefully from the long socket strip.

BU 4 Contact Strip 2 Pol. A-B/3

For building group 1 now install the LED for the battery monitoring and the switch for the battery.

Take 2 pieces of cable from the hardware parts for the system plug connectors and solder a switch to the wire ends of one cable and the LED to the other cable paying attention to the LED polarity, the short leg is the cathode, it is goes to the plug pin 2.

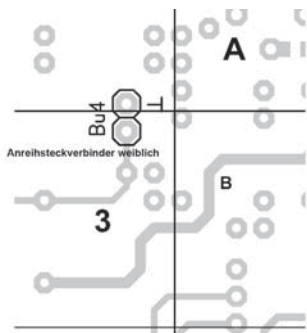

D13                      LED at for cables St6  
 S3                      Switch S3 at for cables St 5

**Do not install/solder ST6** connector to the

circuit board. The height of the connector assembly will interfere with closing the case later on.

Test of the building group: Connect the battery holder to the PLUS and MINUS battery connections (see bill of material P. 16.)

**CAUTION** when using a power supply instead of the batteries!!! Do not forget to adjust to **6V!** The transducer does not easily handle 35V from 13V supply and the transistors survive, at 10V it hangs. With laboratory power supply the current limiting may not be adjusted low enough and since the transducer pulls a high starting current damage may occur before the current limiting responds.

Some Batteries and power supplies have very low internal resistance. This may cause the oscillator not so start. To prevent this situation please add a 1 Ohm/1Watt resistor into the +6V power line. Starting September 22. this resistor is included in the kit (as small as the standard resistors, green body).

Attach switch S3 to St5 — Switch the switch on. Measure the voltage at points named X against ground. The 8 and 10V voltages must be achieved. If both voltages are present, you can continue on with the construction of the building group 2.

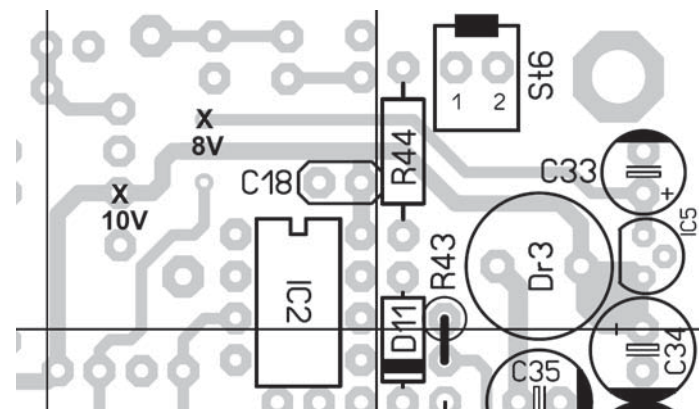

## Building group 2, relaxation oscillator

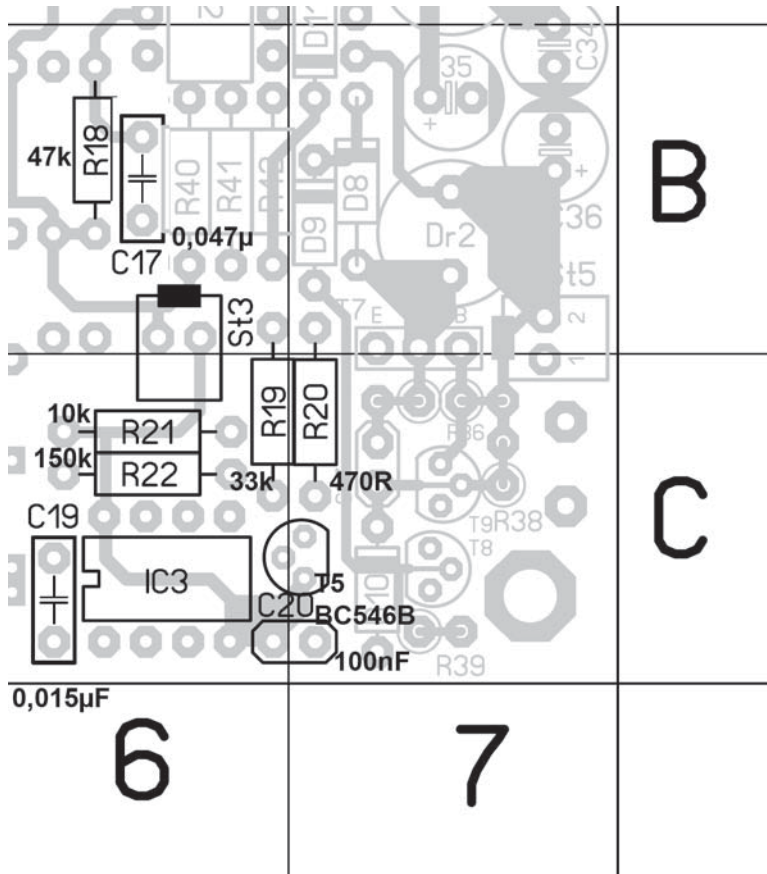

[ ] IC3 C/6 ICM7555 DIL8 w/ PIN 1 Pay attention to the notch  
 Connect switch S2 with cable for plug St3  
 Solder switch 1xEIN on at cable end.  
 [ ] S2

Test Building group 2

Attach Batteries  
 Switch Batteries ON  
 S2 is ON

At IC3 PIN 6 temporarily attach a small capacitor in the nF range to feed a pair of headphones. Expect a signal of approximately 400 cycles per second to be heard. Connect the cap to the emitter of T5, the same signal should be heard a little bit quieter.

If that is ok, then proceed with building group 3

[ ] R18	B/6	47K
[ ] C17	C6/7	0,047 uF foil capacitor (red)
[ ] St3	B-C/6	2-pole Patch cord receptacle pay attention to orientation of plug
[ ] R19	C/6	33K
[ ] R20	C/7	470R
[ ] R21	C/6	10K
[ ] R22	C/6	150K
[ ] C19	C/6	0,015 uF foil capacitor (red)
[ ] C20	C-6/7	100nF
[ ] T5	C.6/7	BC546B

## Building group 3, oscillator, indicator amplifier

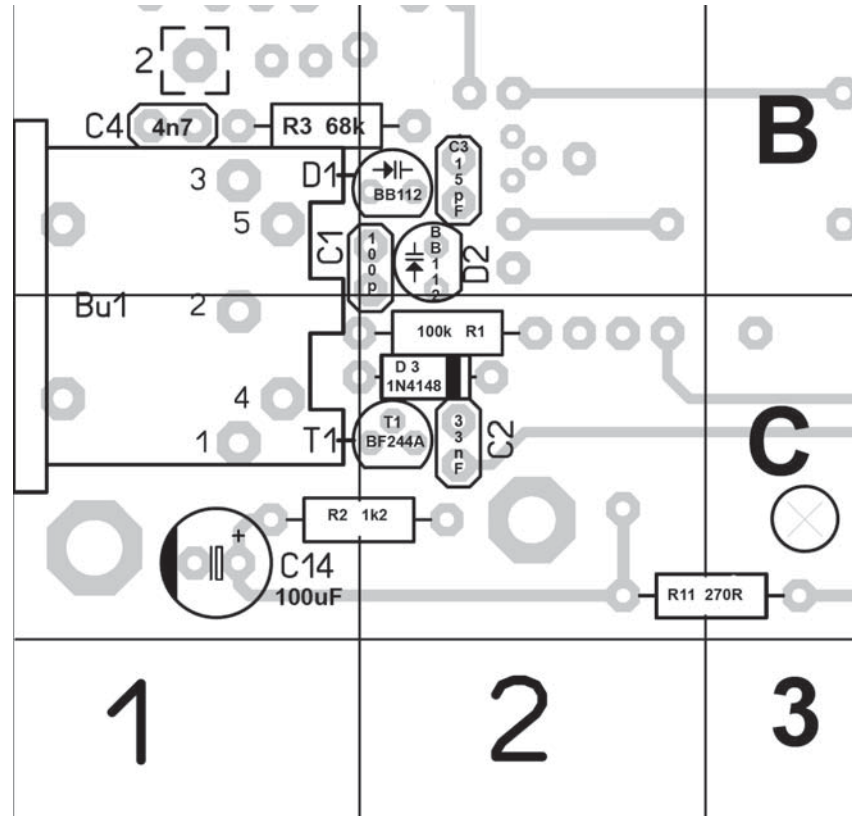

<input type="checkbox"/>	C1	B/1-2	100pF
<input type="checkbox"/>	R1	C/2	100K
<input type="checkbox"/>	D3	C/2	1N4148

<input type="checkbox"/>	C2	C/2	33nF
<input type="checkbox"/>	R2	C/1-2	1,2K
<input type="checkbox"/>	C14	C/1	100uF, pay attention to polarity !
<input type="checkbox"/>	R11	C/2-3	270 R

The following two diodes have TO92 housings and 2 legs. The third leg is rudimentarily present and holds the danger to cause a short-circuit between the two legs of the diode. With this in mind, be very cautious to mount the legs so they do not contact each other or touch the wrong circuit board pads.

<input type="checkbox"/>	D1	B/2	BB112
<input type="checkbox"/>	D2	B/2	BB112
<input type="checkbox"/>	T1	C/2	BF244A

B-C/1 Bu1 print DIN socket

Make sure that the socket is completely flat on the circuit board. Solder only a single socket pin, check the socket position, then solder a second pin and check again. If the socket sits really flat, then solder the remaining pins

<input type="checkbox"/>	C4	B/1	4,7nF
<input type="checkbox"/>		B/1	Solder pin at Position 2
<input type="checkbox"/>	R3	B/1-2	68K
<input type="checkbox"/>	C3	B/2	15pF

November 22.2007

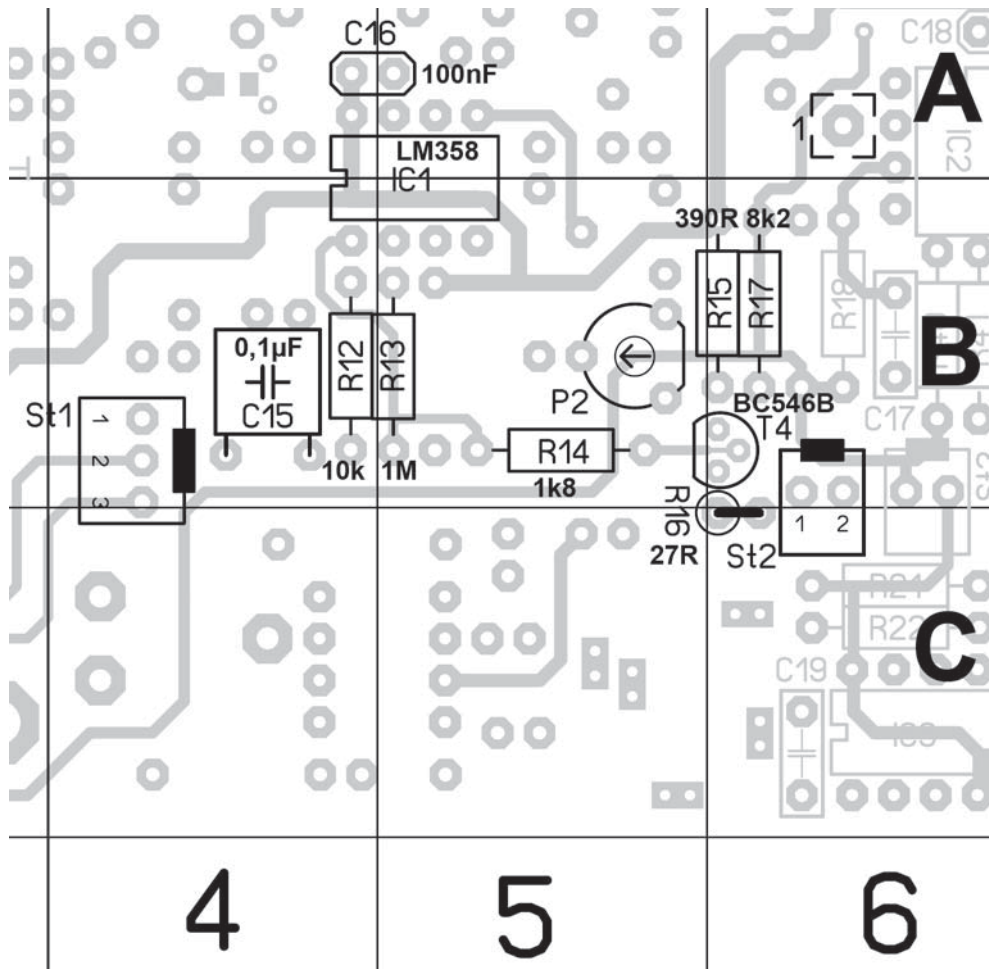

- [ ] C16 A/4-5 100nF
- [ ] St1 B/4 Patch cord, pay attention to tongue
- [ ] C15 B/4 0,1uF insert flat to the pc board!!
- [ ] R12 B/4 10K
- [ ] R13 B/5 1M
- [ ] R14 B/5 1,8K
- [ ] R15 B/5-6 390R
- [ ] R17 B/6 8,2K
- [ ] R16 B-C/5-6 27R standing
- [ ] ST2 B-C/6 System- Patch cord
- [ ] P2 B/5 Trimpot PT6 5K
- [ ] T4 B/5-6 BC546B

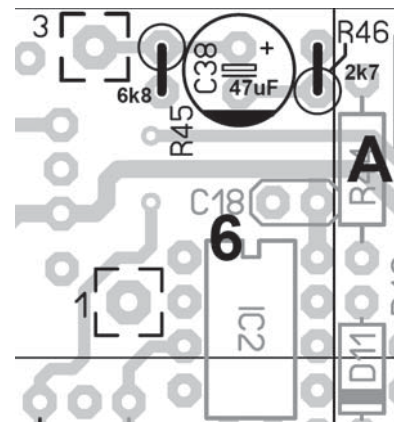

- [ ] IC1 A-B/4-5 LM358 observe pin 1 (notch) position
- [ ] A/6 Soldering pin Position 1
- [ ] A/6 R45 6,8K
- [ ] A/6 R46 2,7K
- [ ] A/6 C38 47uF
- [ ] A/6 Soldering pin on Position 3

Switch S 1 must be soldered to the 3 wires the ST1 plug.  
 [ ] S1 switch

- [ ] Solder three wires, each about 10cm long to the three connections of the 10-turn potentiometer. Solder one of the solder nails sleeves to the end of any wire.
- [ ] Connect the the solderpin sleeves to the responding solder pins. Attention We get different Pot dypes from the supplier, the numbers on the pot do not allways correspond to the solder PIN number. Pin number 2 MUST be connect to the middle connector (variable) of the pot.
- [ ] P5 10K 10-Gang-Pot

Solder the 5mm red LED to the two wire ends of the plug St2. The cathode (short leg) attaches to pin 2

- [ ] D12 LED
- In order to be able to test the building group 3, only one of the 5 Dipper coils must be made. The Dipmeter coil uses a 15.5mm plastic (water) pipe as it's coil form. The pipe diameter can differ from make to make and the dielectric constant of the spool has a certain influence particularly on the higher frequencies. The data listed (frequency range) is approximate and may vary somewhat. The number of the coils may not be sufficient to completely cover entire frequency range. However, with use of the DipIt frequency counter this will not be a problem.

When making the coils measure from the lateral-end of the 15mm coil form to where you will drill the holes for the winding wire. (see Dimensional drawing).

## Spule 3 Bereich 4,6 – 9,7 MHz

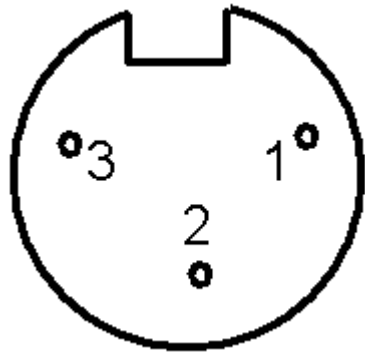
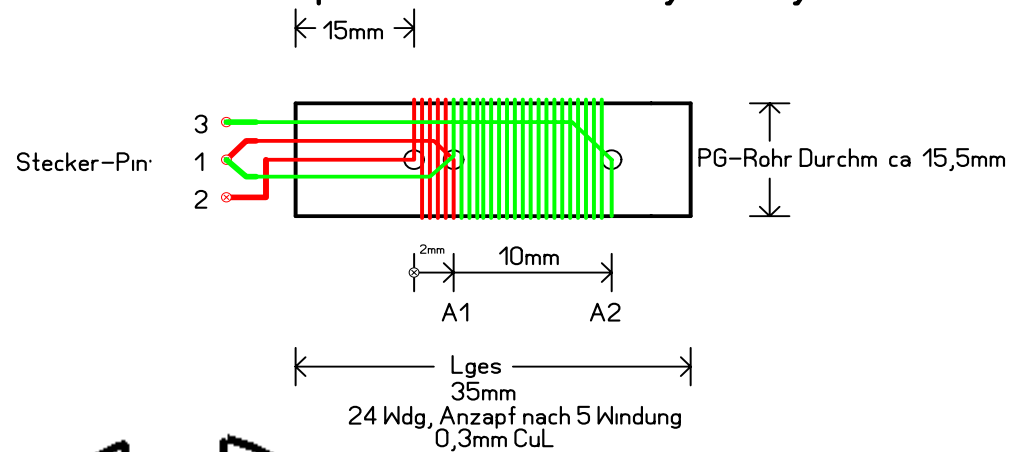

Spule=coil bereich=range stecker=plug  
The enameled wire should be wound evenly with each turn close to the next turn. The wire ends should be kept short then soldered to the pins of the plug base. The drawing here shows the soldering pins of the plugs as seen from the solder side. These plugs are part the 5 pin male connectors provided in the kit. You may discard the metal shields and molded

covers from these connectors.

Attach the pipe after soldering the base plug. Two differently methods can be used:

1. The plug base fits quite snugly up to chamfers into the pipe, but one can press it in with the hand without tools. If the pipe sits straight on the base, then the connection can be durably fastened later with some of the two-component adhesives(epoxy).

Actually we ship two different types of pipes due to some shipment problems of our supplier.

Type 1 has an inner diameter which is a little wider than the black socket. Before glueing the black socket into it, adjust it with 3 small pieces of wood or something similar to sit in the middle of the pipe's diameter. Glue it to its position with epoxy.

Type 2 has a inner diameter which is a little bit smaller than the diameter of the black socket. One can gently heat up the pipe with a heat gun or a hair dryer. The plug base can now be pushed into the pipe up to chamfers. After the pipe sits and cools off the plug base fit will be quite snug, we recommend, nevertheless, the additional use of some type of adhesive. Now take the Dipmeter with the new coil installed and with the help of a receiver tune and listen for a signal. It should lie somewhere between 5 and 10 MHz and you should hear a very strong signal. If you found it, then the oscillator swings. Put the coil aside, it will be completed and aligned after the Dipper is completely built. Assemble now the counter and the indicator boards. You will repeat this test again with the added counter, after completing building group 4.

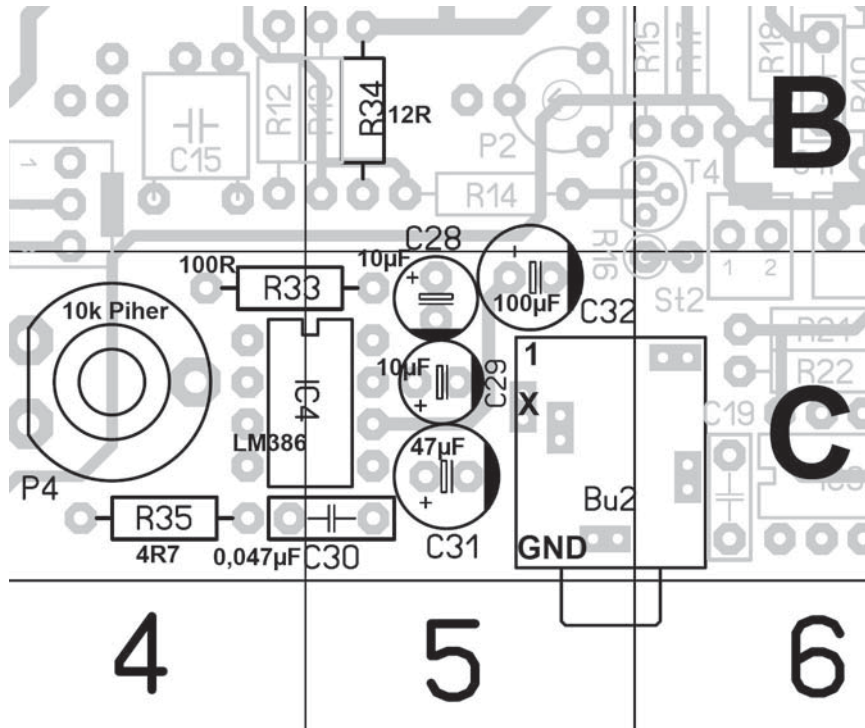

[ ] R34	B/5	12R
[ ] R33	C/4-5	100R
[ ] R35	C/5	4,7R
[ ] P4	C/4	10K
[ ] C30	C/4-5	0.04 uF Foil condenser (red)
[ ] C31	C/5	47 uF rad. Elko
[ ] C29	C/5	10 uF rad. Elko
[ ] C28	C/5	10 uF rad. Elko
[ ] C32	B-C/5	100 uF rad Elko
[ ] Bu2	C/5-6	<b>!! Change: Socket do not install!!!</b>
[ ] IC4	C/4-5	LM386N-1

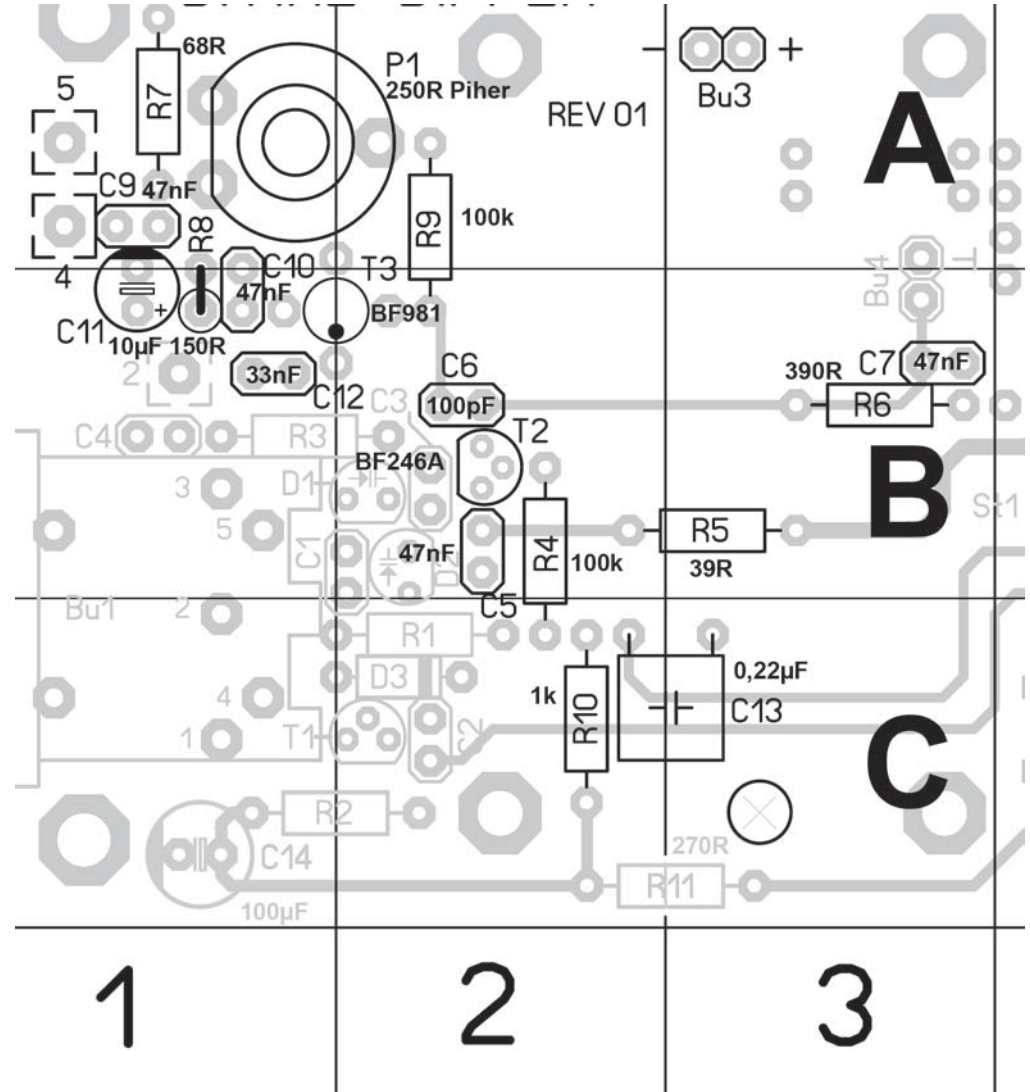

[ ] R7	A/1	68R
[ ] C9	A/1	47nF
[ ] C11	A-B/1	10 uF rad. Elko
[ ] R8	B/1	150R
[ ] C10	A-B/1	47nF
[ ] C12	B/1	33nF
[ ] R9	A-B/2	100K

- [ ] P1 A/1-2 250R
- [ ] C6 B/2 100pF
- [ ] C5 B/2 47nF
- [ ] R4 B-C/2 100K
- [ ] R5 B/2-3 39R
- [ ] R6 B/3 390R
- [ ] C7 B/3 47nF
- [ ] R10 C/2 1K
- [ ] C13 C/2-3 0,22uF Foil capacitor (red) lying flat
- [ ] Bu3 A/3 2 pole female socket, which we break-out carefully from the long socket strip. Solder from the solder side.

Now the dual gate MOS T3. The BF981 is very sensitively to electrostatics, thus consider ESD Measures! The design shows those Arrangement of the Pins as one see sees, from above the dual gate MOSFET. I position of the here clearly sh the BCR all 4 Pins carefully (away from th and solder it.

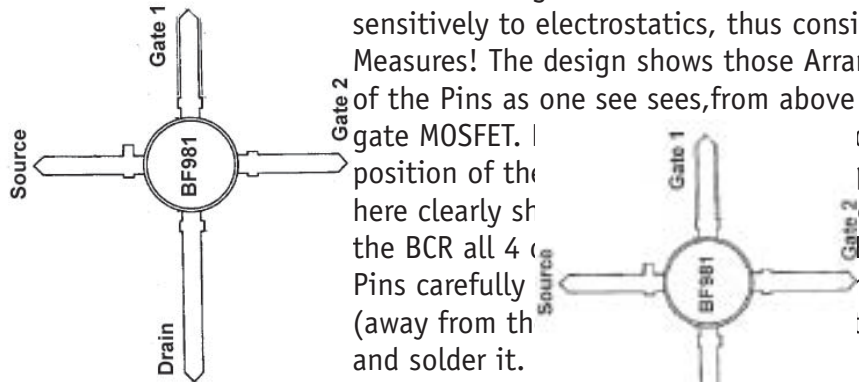

Now the dual gate MOS T3. The BF981 is very sensitively to electrostatics, thus consider ESD Measures! The design shows those Arrangement of the Pins as one see sees, from above the dual gate MOSFET. I position of the here clearly sh the BCR all 4 Pins carefully (away from th and solder it.

- [ ] T3 A-B/1-2 BF981
- [ ] T2 B/2 BF246A
- [ ] A/1 Soldering pin up Position 4 and 5

So that building group 4 functions correctly, the transducer TR1 must be inserted.

**Winding guidance transducer TR1**

Transformer 1 is wound on a double hole core, which among us we jokingly call pig nose. Put the pig nose down in such a way in front of you that the two holes run from left to right. Mark the left side with Nailpolish or other coloured laquer , so that you can again recognize this side later, this side will become the primary Coil. TR 1 receives primarily 6 Turns 0,2mm CuL and secondarily 3 Turns 0,3mm CuL. Cut off a 25cm long piece of that 0.2 mm wire and thread it through the Pig nose, as shown in the picture. Keep

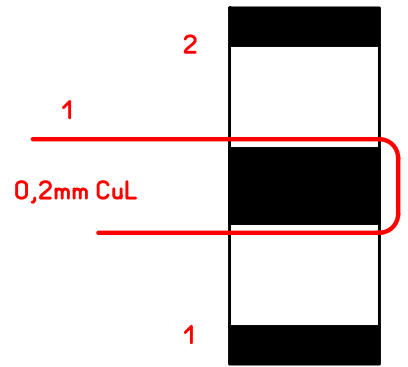

the winding somewhat loose. Pass the wire through the top hole (from left to right) and down through the lower hole (right to left) as shown on the left. This is the first turn.

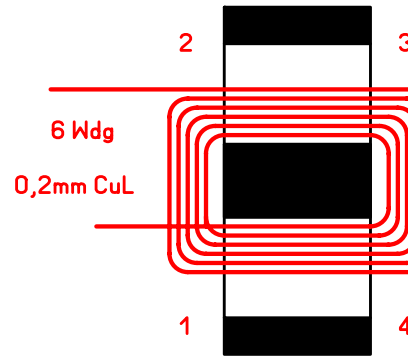

Now continue the wind back up to and through the top hole (right to left) then down again and through the lower hole (right to left) Turn 2 is finished. Do not pull the wire too much over the edges, the lacquer finish on the wire is very thin.. Contine winding in this fashion with turn three, four, five and six and this completes the primary winding.

Still the secondary winding is missing. The secondary winding receives 3 turns from 0,3mm CuL. So that the installation is simpler, our technical designer put on TR1 in such a way that the secondary winding is attached exactly on the side lying opposite.

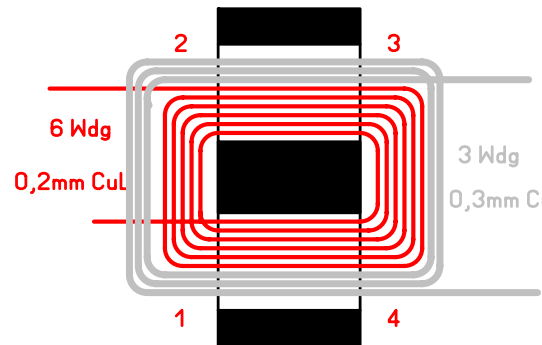

Take a 12 cm long piece the 0,3mm of wire, and lead it carefully from right after left by the upper hole and from left to right by that lower hole again back. The first turn is finished. Repeat this step for turn 2 and again for Turn 3. Remember to keep the windings somewhat loose.

In the next step it is important to completely remove the lacquer insulation from the wire ends. That can be done best with „the Blob“ method. The lacquer decomposes with 350 degrees C soldering iron

temperature. With the Blob method, bring the wire into a thick drop of melted tin solder on the soldering iron point. Start directly behind the ferrite body, keep the wire inside the hot Blob on the soldering point and slowly move the wire to its end. This method eliminates the back and forth scrape to remove the lacquer. One recognizes the beginning of the decomposition process by the ascending Smoke. In this phase move the soldering iron slowly toward on the wire end. As the lacquer burns off, the wire tins at the same time. Use a magnifying glass to determine whether the wire is properly tinned.

The transformer can be now installed. Install it exactly as shown, here and drawn on the pcb. Thread those four wire ends into the holes 1 to 4. Pull the transformer by the wires taut carefully against the board. Check whether with all four tinned wires sit in place within the plated-through holes. The transformer should now lie symmetrically as possible between the 4 holes. If everything is correct, then solder the four wire ends as you hold the transformer in place. After completion of the soldering procedure ensure the transformer lies flat against the board. If it is loose heat the four soldered connections in succession and pull the wires taut.

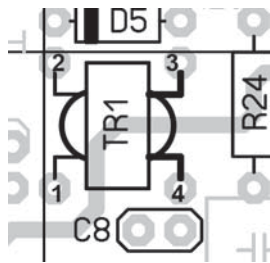

- [ ] TR1 B/4 mini double hole core primary  
6 Wdg 0,2mm CuL secondary 3 turns 0,3mm CuL

For the preparation of the building group test solder a 5cm long piece of RG174 coax cable on to the BNC socket BU5. To the other end of the coax cable solder a 2-plug female socket for connection to soldering pins 4 and 5 at (A/1) pin 5 is ground, pin 4 is the center conductor.

- [ ] Bu5 BNC

The Stereo socket was originally to be installed on the circuit board. After production of the Dipper cases we discovered however our final design wasn't quite right. We did ourselves a favor and moved the socket off board. The Stereo socket now becomes connected by wires to the original circuit board location right beside the battery holder at the end of the dipper

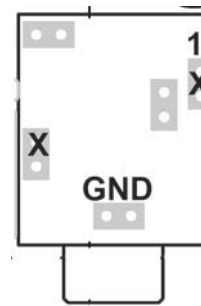

housing. The housings of this series will not have a hole in the side panel. Connect the wires to BOTH points marked „X“ and GND as shown in the layout plan in the picture. Use two twisted wires.

Test building group 4: Attach the battery at the Dipper. Put the coil into the socket for the coil. Put the 10 turn potentiometer to his place, switch on the Dipper. Switch the oscillator off. Switch the Dipper to absorbers. Connect an antenna to Bu5. Plug in Stereo headphones at BU2 set the Volume Pot to the clockwise direction. Place the Attenuation Pot P4 in center position.

If you turn volume potentiometer up now slowly, then you should hear some broadcasting stations. The Dipper works now like a direct superheterodyne receiver on short wave within the range of the coil being used. Naturally it does not have a much selection, and it you will hear overlapping signals. In our attempts with DipIt prototypes and using a Z-match we heard CW and SSB QSOs without problems.

## Frequency counter and announcement

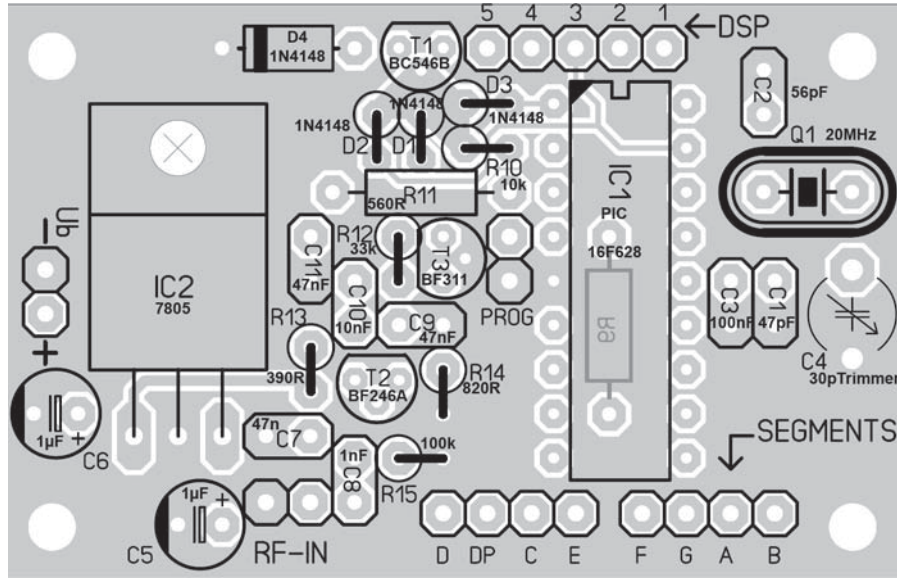

Put the plate down before you in such a way, as seen on the design, so that you can always orient yourself. Do not insert the contact strips yet, you see some characteristics to consider. Solder R 9 as the first the resistance. You see it here on the design (as writing in a mirror) drawn inside the outline of IC 1, that means, it belongs on the solder side of the plate.

[ ] R9 10k Install on the solder side and solder on the component side. Cut the Pins off after soldering very close to the soldering plates. The remaining parts are installed normally from the component side. Begin in the left, upper corner. All parts must be installed close to the board otherwise the will be problems later when plugging the boards together.

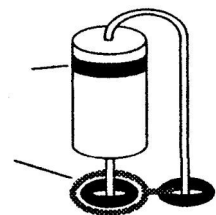

[ ] D4 1N4148 - It makes sure that the Band mark (cathode end) is oriented as in the design.

[ ] D2 1N4148 Upright. With standing diodes the band stamp shows the cathode upward and the diode body is mounted where the circle is drawn..

[ ] D1 1N4148 standing, exactly the same as D2

[ ] D3 1N4148 standing, the same as D2/D3

[ ] R10 10k install, likewise standing

- [ ] R11 560R lying
- [ ] C11 4 7 nF (473)
- [ ] C10 10 nF (103)
- [ ] R12 33k (possibly later up T3 UCE 2,5V adjust)
- [ ] C9 47nF (473)
- [ ] R13 390R
- [ ] R14 820R
- [ ] C7 47nF
- [ ] C6 1uF Elko, respect polarity long leg = PLUS
- [ ] C5 1uF Elko, pay attention to polarity
- [ ] C8 1nF (102)
- [ ] R15 100k
- [ ] C2 56pF

[ ] Q1 20 MHz quartz. Place two cut off resistor leads under the crystal to support the assembly a small distance up from the circuit board. This space will prevent the tin solder from creating a short-circuit between crystal and printed circuit board. Do not forget to pull the wires out again after soldering.

- [ ] C3 100nF (104)
- [ ] C1 47pF (47p, 47j)
- [ ] C4 30pF foil trimmer

Now the base for the microprocessor. Make sure that the notch in the base is oriented in such a way, as seen in the design.

[ ] Socket IC1

Sectional drawing, part facing downward, seen by the broadside  
2x4 link female

1x2 ink male Connection sockets are installed on both sides of the display board.. They must make the connection to both the motherboard and to the dis-

Schnittzeichnung, Bauteile nach unten ,von der Breitseite gesehen

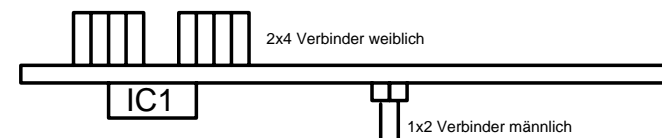

November 22.2007

play board. It best done if one builds, aligns completely the two boards together using the plug connectors and enclosed spacers before soldering. For the connection to the display we take the female links.

Install counter plate one Since hanging, thus with the parts to the Hauptplatine showing the. The 1x5 and 2x4 link are installed on the solder side and soldered on the component side. Make sure that the links stand as perpendicular to the circuit board as possible. Solder only one pin, align the group and then solder the remainder.

Solder on the component side:

- Link 5.4.3.2.1 (female)
- link D, DP, C.E (female)
- link F, G, A, B (female)

Now the two links to the motherboard. They are installed on the component side and soldered on the solder side. Pay attention again to install it exactly perpendicularly.

- Link Ub (male)
- link RF-IN (male)

Install the remaining semiconductors:

- T1 BC546B
- T2 BF2546A
- T3 BF311

The Voltage Control IC2 = 7805 generally speaking T0220 housing. Now the Processor can be put into the base. Remember, this part is very sensitive to electrostatics, pay attention to the ESD rules.  **PIC 16F628**

That was the counter, now the display board must be soldered before we

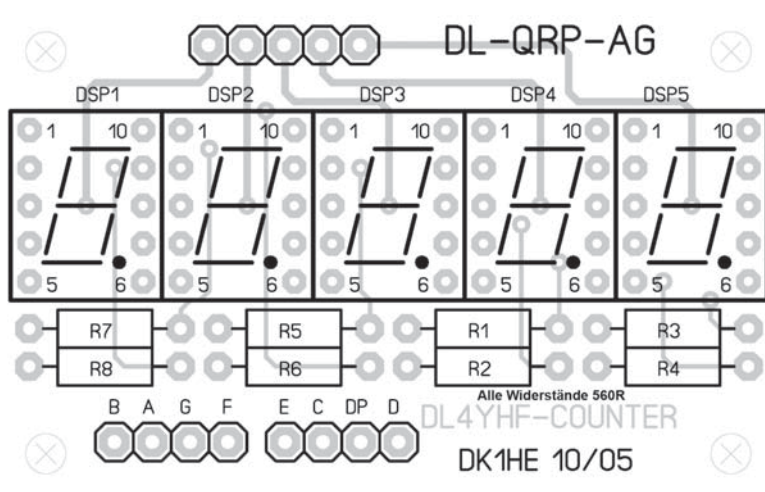

can test everything together. Here there are only few parts. Begin with the resistances. The component side has the label DL4YHF :

- |                             |      |                             |      |
|-----------------------------|------|-----------------------------|------|
| <input type="checkbox"/> R1 | 560R | <input type="checkbox"/> R2 | 560R |
| <input type="checkbox"/> R3 | 560R | <input type="checkbox"/> R4 | 560R |
| <input type="checkbox"/> R5 | 560R | <input type="checkbox"/> R6 | 560R |
| <input type="checkbox"/> R7 | 560R | <input type="checkbox"/> R8 | 560R |

Now the 5 pieces of seven segment displays. Do not insert them upside down. You will see a decimal point on the bottom right of each announcement. Place a display unit into the circuit board, as shown in the design. Press the announcement firmly against the circuit board while soldering and solder only two pins diagonally opposite each other. Check whether the announcement really mounted flat, and correct if necessary, by re-heating the two soldered connections. Then solder the remaining pins. Proceed with all 5 display units in accordance with this method.

- DSP1
- DSP2
- DSP3
- DSP4
- DSP5

Now the links. All three connector groups are installed on the solder side and soldered on the component side. Since they connect to the counter board and you installed female links there, logically you must use now use male connectors. Again make sure that they sit accurately perpendicular.

- Link 5 pin (male)
- Link 4 pin (male)
- Link 4 PIN (male)

You can temporarily put the three plates together now. The motherboard on the bottom, whereupon the counter board (parts side towards the motherboard) and on the top the display board (announcements upward). If you repeat the building group 3 test now, you will have a digital frequency display.

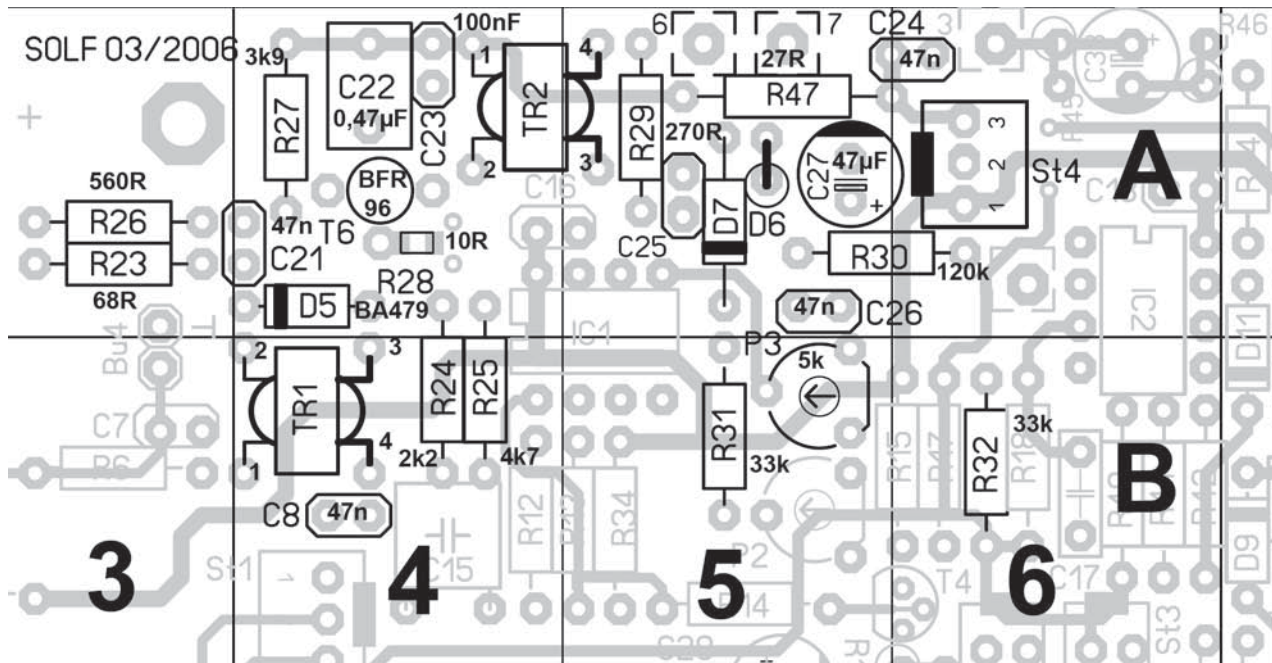

[ ] D6	A5	AA143, GA103 or similar.
[ ] C25	A/5	10nF
[ ] C24	A/5-6	47nF
[ ] C27	A/5	47 $\frac{1}{4}$ F
[ ] St4	A/6	System- Patch cord
[ ] R30	A/5-6	120K
[ ] C26	A/5	47n
[ ] R31	B/5	33K
[ ] P3	B/5	5K Trimpot
[ ] R32	B/6	33K

Now transformer TR2. It is wound exactly the same and inserted, as it was described with Tr1.

### Building group 5

[ ] R26	A/3	560R
[ ] R23	A/3	68R
[ ] R28	A/4	10R

The only small SMD part, installs in the middle in the field. Please solder only on the right side (left side unsoldered), so that the hole for T6 is not clogged by solder tin.

[ ] R27	A/4	3,9K
[ ] C22	A/4	0,47uF Foil condenser
[ ] C23	A/4	100nF
[ ] C21	A/3-4	47nF
[ ] D5	A/4	BA479
[ ] C8	B/4	47nF
[ ] R24	B/4	2,2K
[ ] R25	B/4	4,7K
[ ] R29	A/5	270R
[ ] R47	A/5	27R

On the board with DR1, designates replacement)

[ ] D7	A/5	AA143, GA103 or similar.
--------	-----	--------------------------

Caution, the glass body breaks easily!

[ ] TR2 A/4-5 mini double hole core primary 6 Wdg 0,2mm CuL secondary 3 turns 0,3mm CuL  
Now transistor T6. This is very sensitive to ESD. Insert T6 so that you can see the writing from above and carefully bend the three Pins downward perpendicularly. Set T6 into the three holes, the writing must remain readable otherwise the transistor is mounted backwards.

[ ] T6	A/4	BFR96S
Now do not forget, to solder the left side of the SMD transistor R28!!!!		
Install the two soldering nails in positions 6/7		
[ ] Soldering nail	A/5	Position 6
[ ] Soldering nail	A/5	Position 7

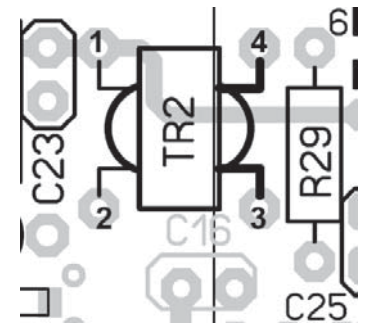

Temporarily solder two wires to ST4 from the switch S4. Solder a 5cm long piece of coax cable to a Phono socket. Solder the other end to the soldering nails at positions 6 (center conductor) and 7 (ground).

## Test building group 5

Attach the battery and all switches used so far to DipIt. Put the frequency coil already manufactured into the base. Connect Bu6 (HF generator output) to a dummy load (can be small dummy load as we produce only QRPppp, 7dBm).

Switch the Dipper on.

Switch the relaxation oscillator out (S2)

Switch the mode selectors to „Dipper „

Measure with a high impedance voltmeter the DC voltage at IC1 pin 5 and adjust it with the trim potentiometer P3 to as close as possible to 700mV. (For this manual: exact value still to be determined). Thus the output of the generator is adjusted to +7dBm according to 500mV EFF HF at 50 ohms. (D6/D7/C26/C27 form a HF probe, which changes the HF voltage into DC voltage as it heads to the automatic control loop, which keeps power output constant.)

### **Alignment work:**

There are actually only three places, which can be adjusted:

1. P2 in the indicator amplifiers building group. P2 is adjusted in such a way that the breakdown voltage of the diode without control is reached by the Dipper. In addition the coil is taken off and P2 adjusted in such a way that the LED just „visibly glows“. The whole naturally in position „Dipper“ and „Oscillator“
2. The Dipper With a counter it does not depend on a few Hertz. One can adjust the indicated frequency by means of the trimmer C4 on the counter board in comparison to a reliable external frequency source
3. The +7dBm amplifier. The power output of the amplifier is limited using the trim potentiometer P3, see accompanying description.
4. For sensitivity increase the oscillator can be increased somewhat, if R15 is made smaller on by approximately 15kOhm. . It is enough to solder a 27k resistance parallel to R19.

## Production and calibration of the coil spool.

The measuring range is overlapping, starting with low frequency with coil 1 and continues upward. You have already manufactured coil 3. The Dipmeter coil uses a 15.5mm plastic (water) pipe as its coil form. The pipe diameter can differ from make to make and the dielectric constant of the spool has a certain influence particularly on the higher frequencies. The data listed (frequency range) is approximate and may vary somewhat. The number of the coils may not be sufficient to completely cover entire frequency range. However, with use of the DipIt frequency counter this will not be a problem.

After completion of the coil, coat the coil with a thin coat from eagle owl pluses or similar adhesive to protect against environmental influences. The plug is stuck into the pipe and slid up to chamfers.

One can gently heat up the pipe with a heat gun or a hair dryer. The plug base can now be pushed into the pipe up to chamfers. After the pipe sits and cools off the plug base fit will be quite snug, we recommend, nevertheless, the additional use of some type of adhesive.

Reel 1: 19 MHz-40MHz

### Spule 1 Bereich 19-40 MHz

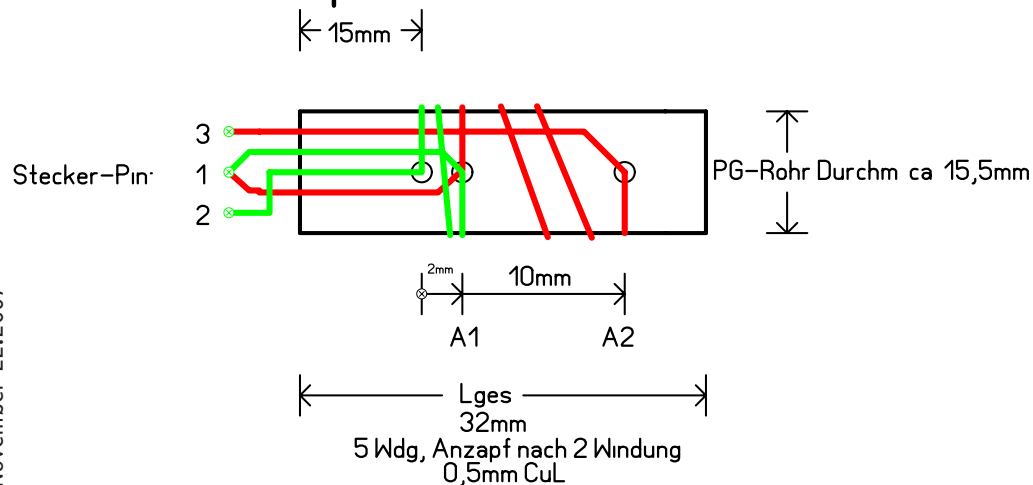

$L_{ges} = 32\text{mm}/A1 = 2\text{mm}/A2 = 10\text{mm}$  Total total: 5 Wdg 0.5 mm of CuL, tap with 2. Spread the turns to result in a max.-upper frequency of approx. 40 MHz. Measure this with the Dipmeter counter.

Reel 2: 9,45 MHz-19,4MHz

### Spule 2 Bereich 9,4-19,4 MHz

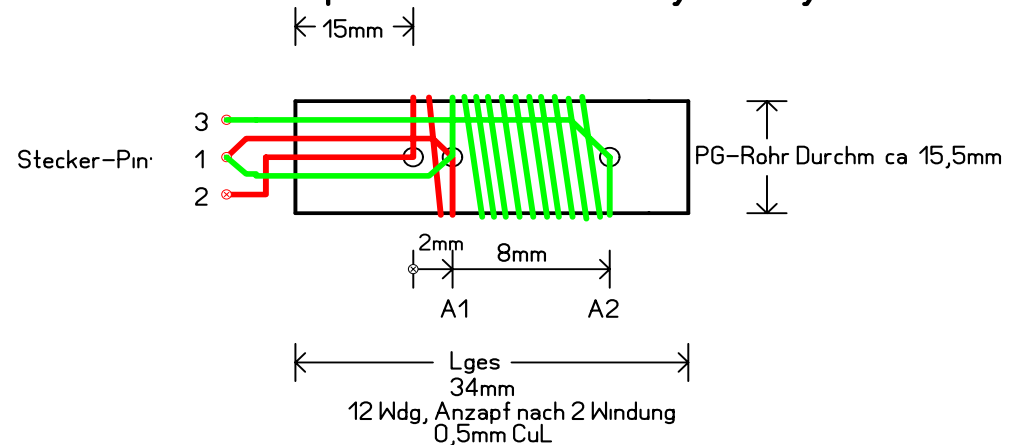

$L_{ges} = 34\text{mm}/A1 = 2\text{mm}/A2 = 8\text{mm}$

Total total: 12 Wdg 0,5mm CuL, tap with 2.

Spread the turns of the cold end. The turns must be spread in such a way that the highest adjustable frequency lies somewhat higher than the lowest frequency of coil 1.

Reel 3: 4,65 MHz-9,73MHz

$L_{ges} = 35\text{mm}/A1 = 2\text{mm}/A2 = 10\text{mm}$

Total: 24 Wdg 0,3mm CuL, tap with 5. Turn of the cold end

The turns must be spread in such a way that the highest adjustable frequency lies somewhat more highly, as the lowest adjustable frequency of coil 2.

### Spule 3 Bereich 4,6 – 9,7 MHz

← 15mm →

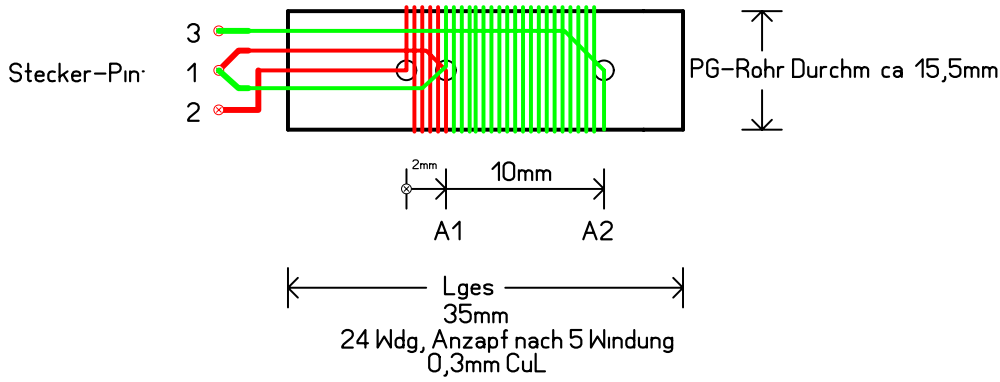

Coil 4 and 5 are wound in the same manner, we did not not make drawing for coils 4 and 5 because it wasn't clear due to the high numbers of turns.

Reel 4: 2,44 MHz-5.05MHz

$L_{ges} = 45\text{mm}/A1 = 4,5\text{mm}/A2 = 23\text{mm}$

Total total: 62 Wdg 0,3mm CuL, tap with 12. Turn of the cold end.

People have asked us why we do not use a coil with ferrite core, which would lower the number of turns dramatically. The answer: we wanted to build here a high-quality measuring instrument useful to us. A coil with ferrite core would bundle the lines of flux strongly inside the coil and is exactly that an effect, which we can need with a Dipper in no case. With an air core the lines of flux spread unrestrainedly outward, which makes it substantially more sensitive and thus make unloaded measurements possib-

le. Always remember: the more strongly the item under test is loaded, all the more strongly it changes its resonant frequency, all the more wrongly is our result of measurement.

Reel 5: 1,25 MHz-2,56MHz

$L_{ges} = 35\text{mm}/A1 = 2\text{mm}/A2 = 11\text{mm}$

Total total: 95 Wdg 0,1mm CuL, tap with 19.

Turn of the cold end Who would like itself to manufacture a coil for the old ZF 455 kHz, accordingly many turns on a further spool winding must. Remember, no ferrite use. The coil may be wound also 2-lagig.

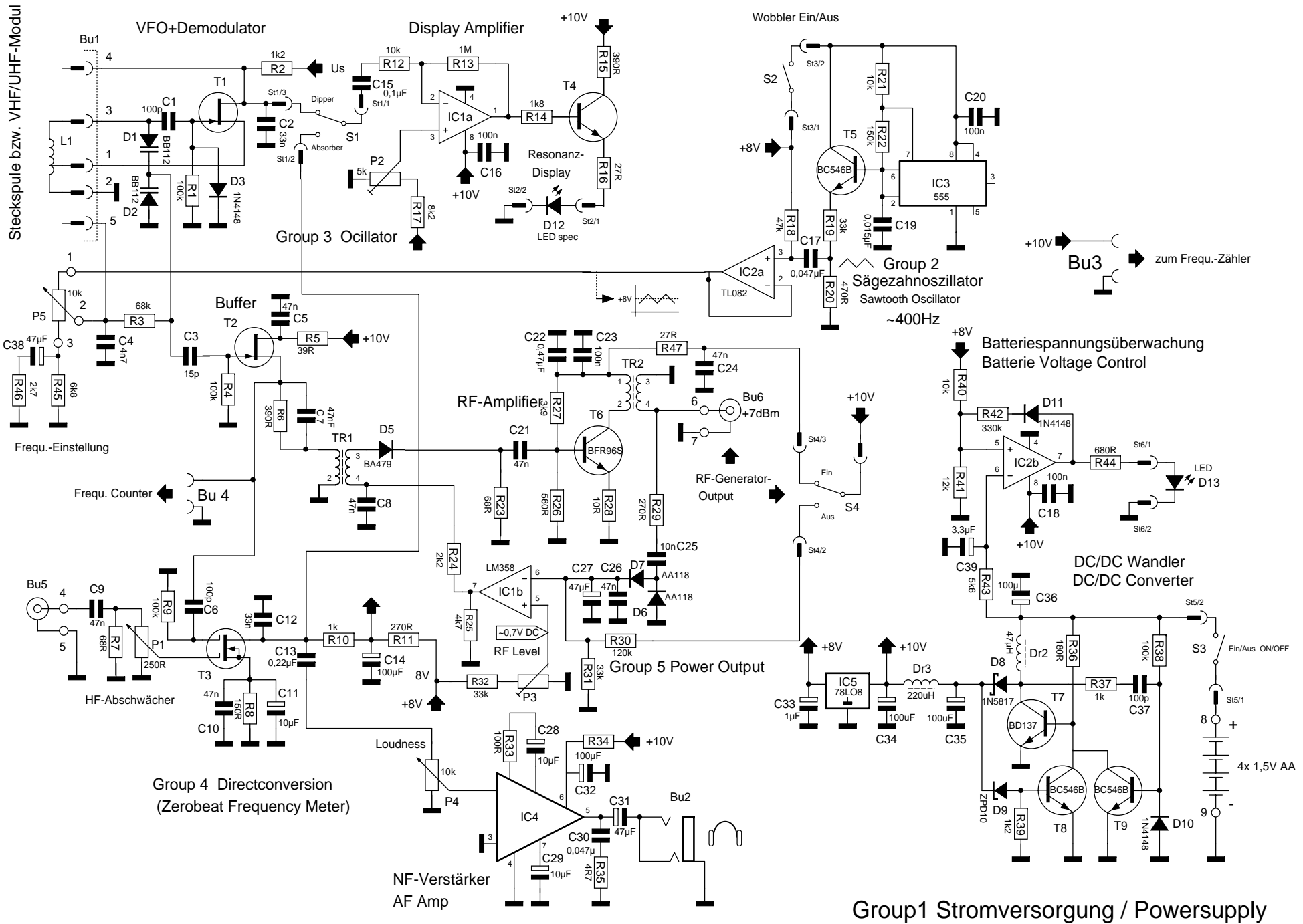

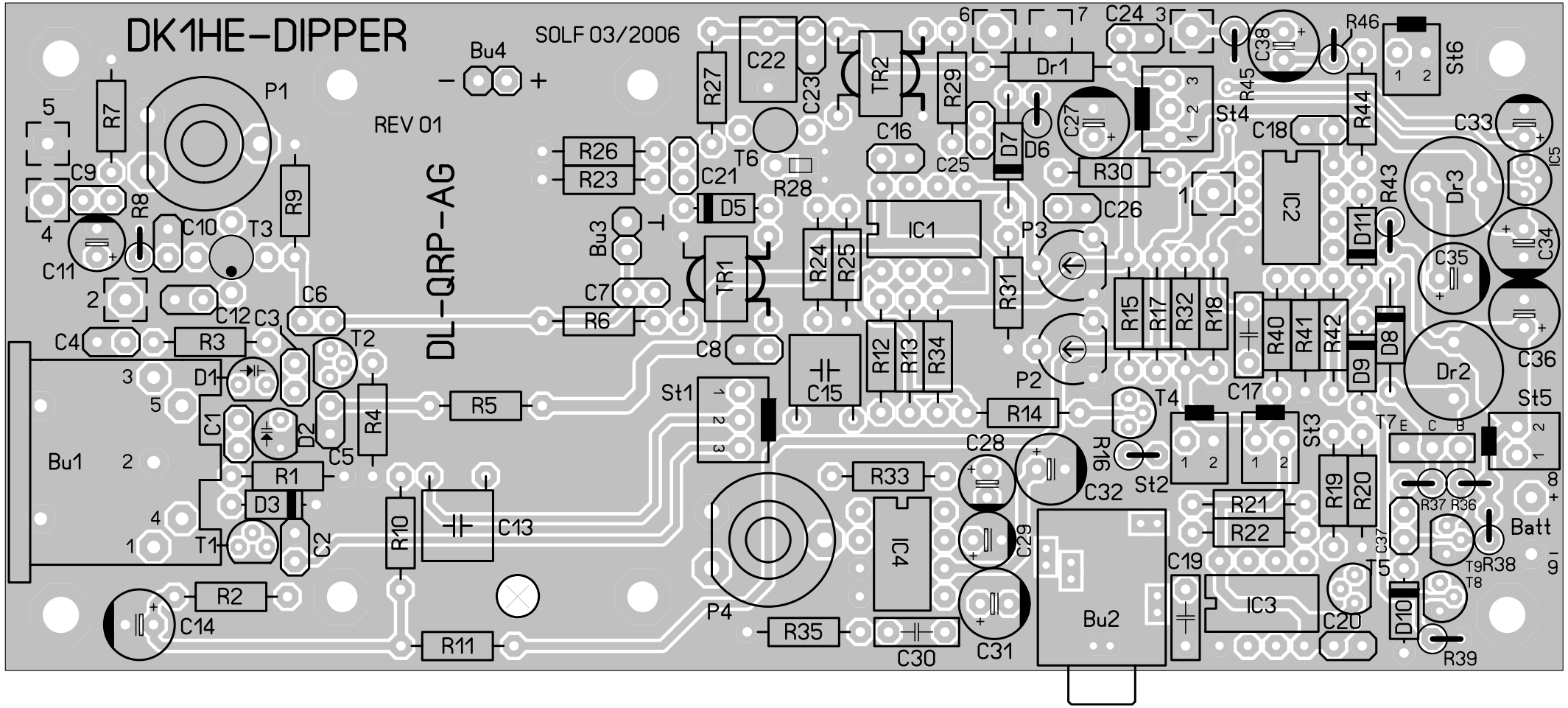

# DL4YHF-Counter

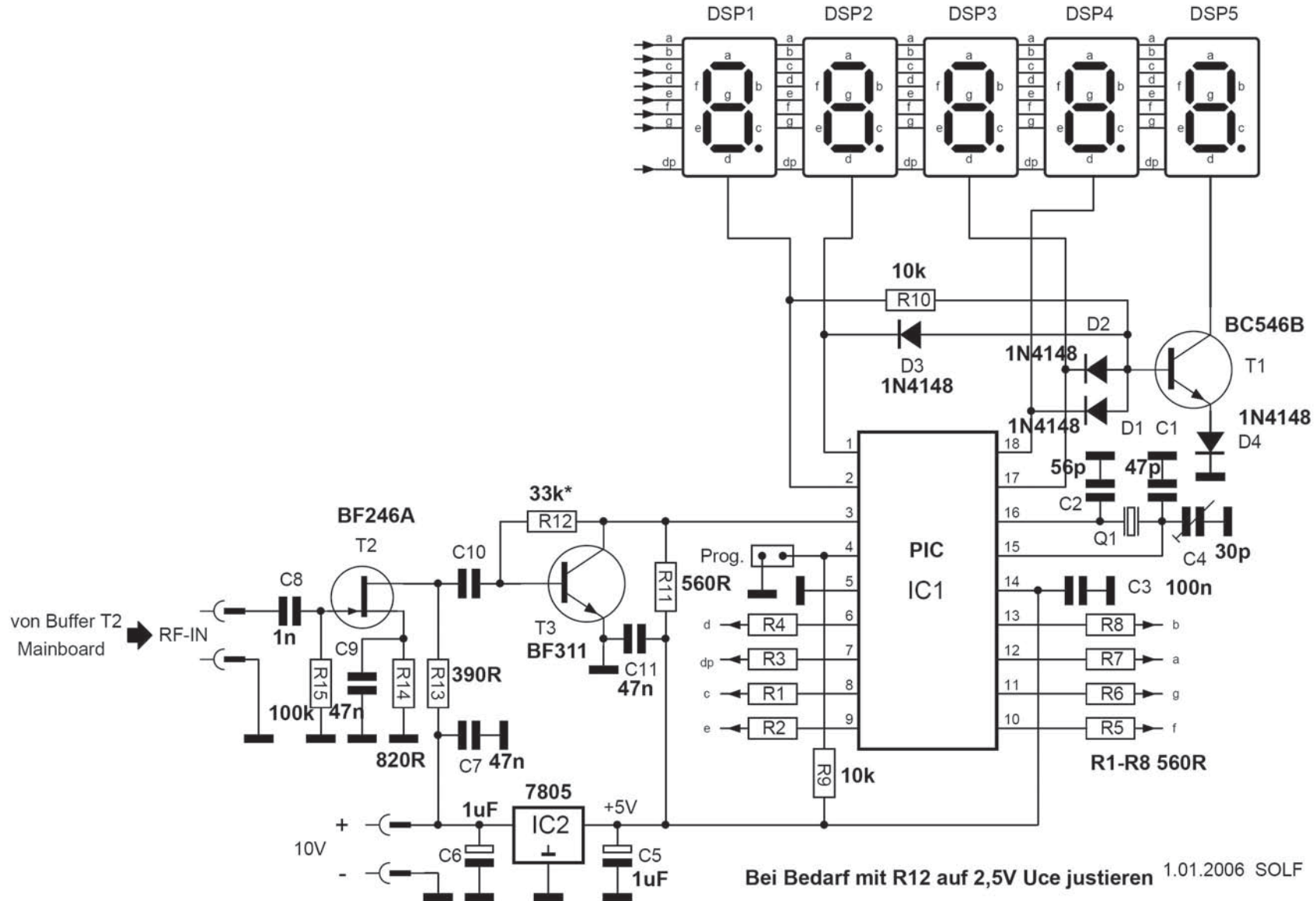

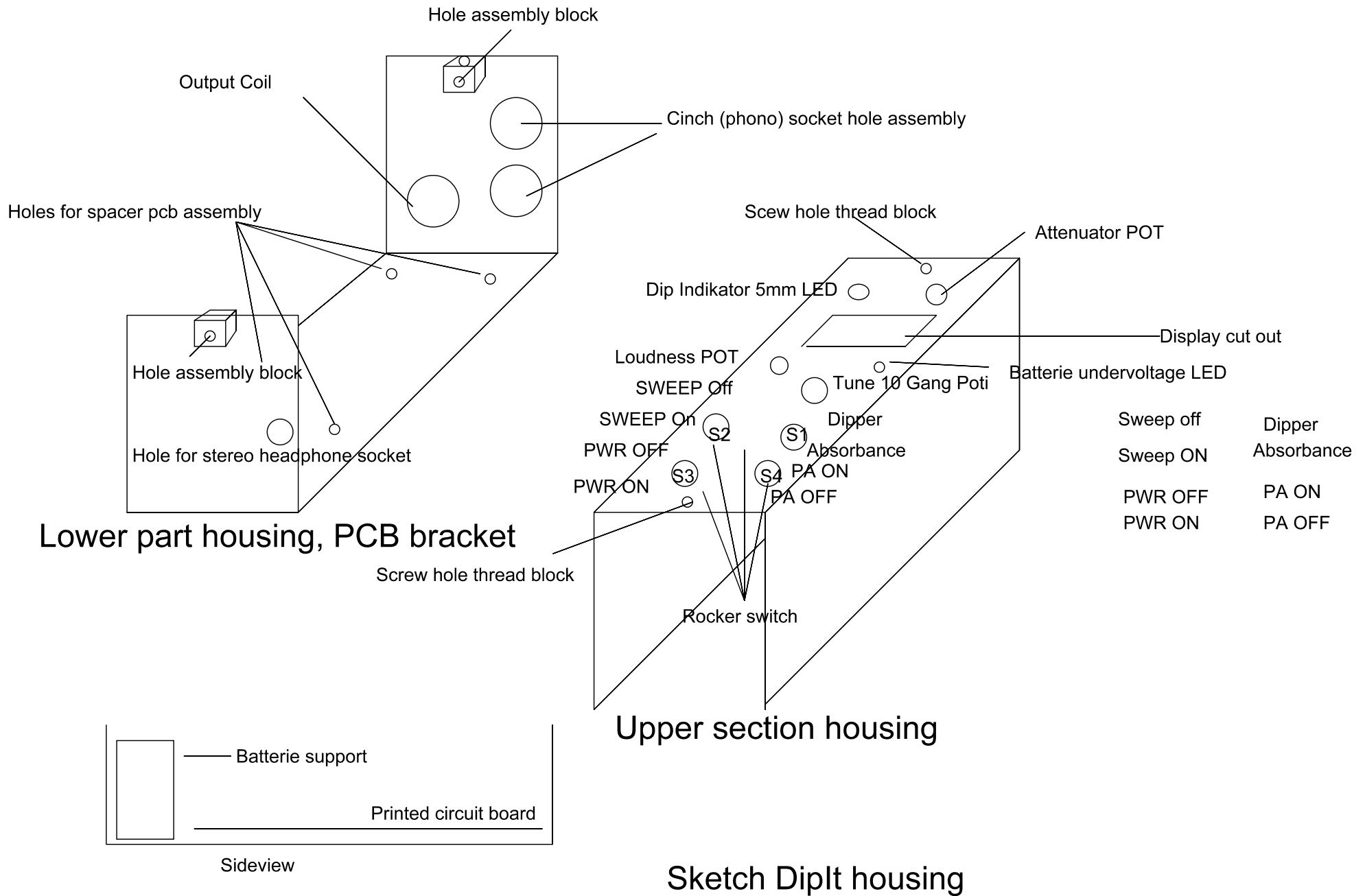

# Dipit Coil



to ST1

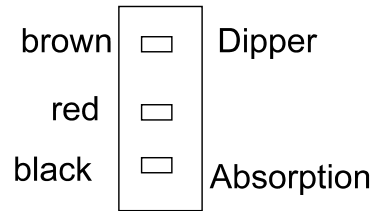

to St 3

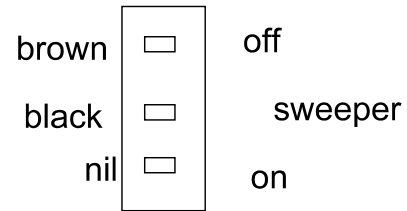

to ST4

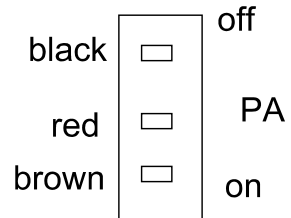

to ST5

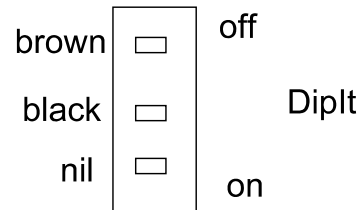

Switches seen from solder side

Shorten the cables and solder the colours as shown in the drawing

Attention: switches are sensitive against too much heat

At the battery support attach the ground to screw. For the sake of insulating use tape or a piece of pasteboard(cardboard), it could otherwise Short-circuit with the housing, the same is also recommended with the jack headset-phone and the screw in the thread block against the battery. Because of the housing tolerances the thread block presses the edge on the battery it's recommended the thread block edge be pushed diagonally

Install the first the circuit board into the housing. Use for it the 5mm spacer. The battery support comes into the housing bowl at the lower end of the circuit board. Connect the red wire of the tie-clip with pin 8 and the black wire of the tie-clip with pin 9 of the circuit board (take in addition ever one of the provided Steckschuhe)

Connect a 1xUM switch with the help of to three-wire cables/plug combination with St1. The switch is S1, it switches between Dipper/absorber

Connect a 1xUM switch with the help of to two-wire cables/plug combination with St3. The switch is S2, for the Oscillator.

Connect a 1xUM switch with the help of to two-wire cables/plug combination with St5. The switch is S3, the battery main switch. Connect a 1xUM switch with the help of to three-wire cables/plug combination with St4. The switch is S4, circuit breakers for the +7dBm amplifier.

Connect the 10-turn potentiometer with the pin 1,2,3. Use the lugs. Build the jack headset-phone into the foot of the bottom case (beside the battery pack)

Connect the 5mm LED with the help of a 2-wire cable/plug combination with St2. The cathode (short leg) goes on ST2/2, that is the ground side. Use the plastic LED grommet for mounting the assembly in the case. Connect the 3mm LED with the help of two wires with the circuit board drillings at the position St 6. St6 may not be installed, since otherwise the switch fits above and the housing cannot not be closed. The short leg (cathode) comes into the drilling St6/2 (ground side) A Cinch (phono) socket screws into the front wall of the lower shell and connects the interior pin with pin 4 and the ground connection with pin 5. This phono socket is the input to the overlapping frequency meter. The second Cinch socket screws into the front wall and connects the interior pole with pin 6 and the ground side with pin 7. This Cinch(phono) socket is the output of the

+7dBm of amplifier. The housing is bolted with the two pedestals. The ground side of the pedestal for the side with the battery support points to the batteries.

**Calibration of the +7dBm of amplifier.** The amplifier can be calibrated very exact by its inserted HF probe and the rule loop. Switch the Oscillator off. Terminate the HF output with 50 ohms. If you do not have QRP dummy load (e.g. the thermal wattmeter), then use a non-wirewound (carbon) 50 ohms resistor. Switch on the HF amplifier. DC voltage measures at IC 1 pin 7 and adjust it with the trimmer P3 to exactly xxx millivolts. At the output of the Dipmeter now a very exactly +7dBm lines up.

**P2 in the display amplifiers building group.** P2 is adjusted in such a way that the breakdown voltage of the diode without control is reached by the Dipper. In addition the coil is taken off and P2 adjusted in such a way that the LED just „visibly glows „. The same in position „Dipper „and „Oscillator“  
**Attitude of the counter:** With a Dipper it does not depend on a few Hertz. One can adjust the indicated frequency by means of the trimmer C4 on the counter board in comparison to a reliable external frequency source.

If you already know how to use a Dipmeter, then you can now proceed. If not, then look at the provided QRPproject manual CD (unfortunately it's in German only). Under DipIt you find a collection of articles Dipping and using a Dipper. Don't let it bother you to that all the literature is from the years 1965 to 1975, it also add a few newer things. Apart from the fact that Dipping was more heavily used in the past with older equipment (sensitivity frequency dial etc.) all the described methods directly transfer to uses today.

If you read all this and tried it out you will have fun with the DipIt and then can also say:

I Build the DipIt

We wish you much fun and Dipping

The QRPproject team