



## K2 SSB Modifikation

A compilation of the mods suggested by John, KI6WX, Karl-Heinz, DF7KHK and Frank, DJ3FR by DL2FI

During the time there have been several suggestions do modify the SSB Modul of the K2 do improve the the modulation which is named „a little bit weak and sometimes crasy by some users. Well known and often used are the mods designed by John, KI6WX and Karl-Heinz, DF7KHK. The Mod regarding the bandwith of the Xtal Filter suggested by John have been overtaken for the series kits by elecraft some years ago.

The following description is a compilation of different mods. Frank, DJ3FR had the chance to test all known SSB mods using a set of ten K2/100 which haven been built at the same time during a student course. The described combination of mods if have been installed guarant a clean, strong modulation on all bands. I have modified and tested a lot of K2 when servicing them as QRPproject supporter. The Berlin DXpedition Gang is using now 3 modified K3/100 for DXPeditions e.g. to XV4D 5H1DF, A25/DL7DF say they now get reported a „modulation like a man“ :-)

### Improving the Quality of the modulation, Solving the problem of less driver power on the upper bands

The following description belongs to:

1. Serialnumber K2 above > 3000  
or if lower number installation of XFILMDKT 2nd Filter SSB Modification Kit.
2. SSB PCB as describes in Manual Rev E July 20, 2004 or newer  
(That means the new Xtals must be installed, caps CC and CM = 27pF, CG, CH, CE, CK, CA, CP = 39pF)

If you modify an older K2, in any case check the Xtals on the RF board. They must be signed with the same sign (4,915-S) as the Xtals on the SSB board. If not, they must be replaced by the newer Xtals.  
Elecraft number for replacement: K2KSB2XTLS 14 pieces paired Filter Xtals coplete for main board and SSB board

Here we go, start with John´s Modifikation:

#### MOD 1: KSB2, More Gain for SSB

The original SSB board has a little bit low gain. If a mirophone with low output is used, it cannot drive the K2 to full power at the high frequency bands. Using microphones with higher levels it can happen, that the NE602 is over driven with causes AF clipping. This mod is a clean solution for both problems.

John is using a PN2222 Emitter follower to cople the NE602 to the low impedance side of transformer T2. This way he uses the Voltage transformation of T2 and gives a much lower load to the NE602 output stage. The 82 Ohm resistor together with the impedance of the Emitter follower gives a good Imedance matching for the Xtal Filter. The resulting gain of this mod in total gives a plus of about 10 dB..

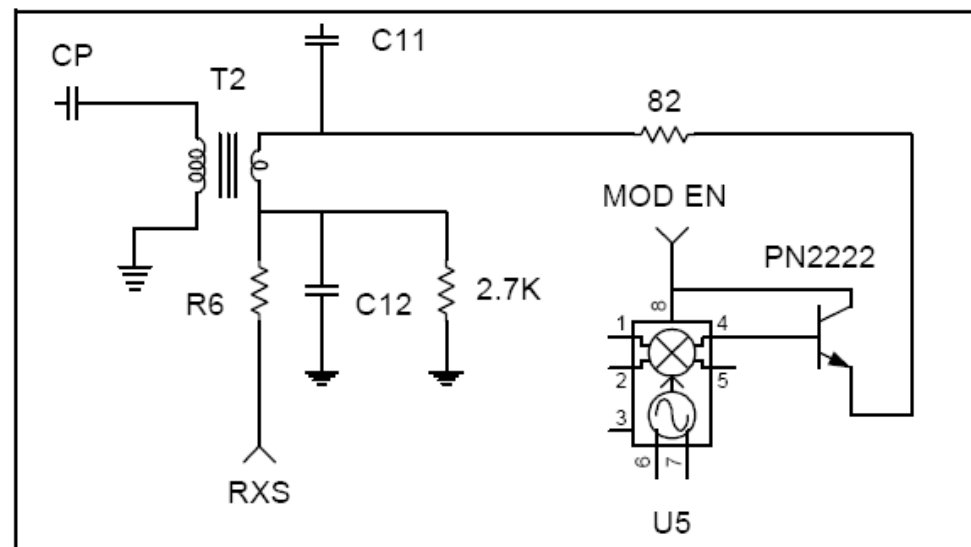

The mor is easy to realize:

- [ ] **Remove D4**
- [ ] Desolder wire number 2 and wire number 4 of T2 ( you find them next to the NE602).
- [ ] Now solder former number 4 wire to solderlug number 2 and former

number 2 wire to solderlug number 4. This will reverse T2 by 180 degrees.

[ ] Install a **PN2222** (attention, 2N2222 has another pinning). Place it at the right side of NE602 the flat side orientated towards NE602. The 3 Pins look upwars.

[ ] Solder colector to PIN 8 of NE602

[ ] Solder Base to PIN 4 of NE602

[ ] Solder a 82 Ohm Resistor between Emitter and PIN 1 of T2. Use the solderlug of C11.

[ ] Solder a 2,7kOhm Resistor between wire 4 of T2 and ground at the solder side of the PCB. ( Use the junction between R6 and T2/4. This resistor will hold the Base/Emiter junction of PN2222 at 3V to avoid Base/Emitter breakthrough.

Alternativ you can do this mod complete at the solderside of the PCB as shwn in the picture below.

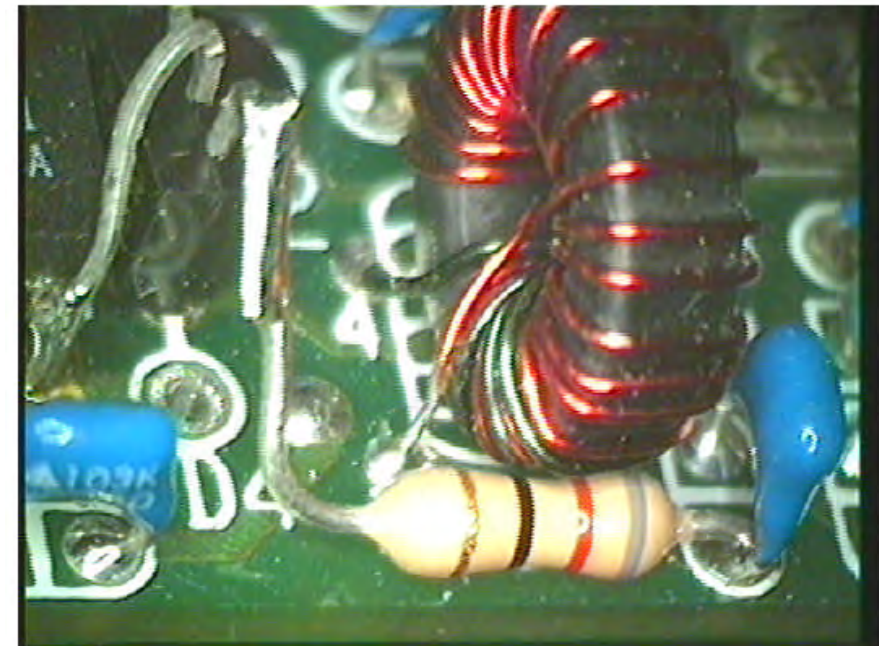
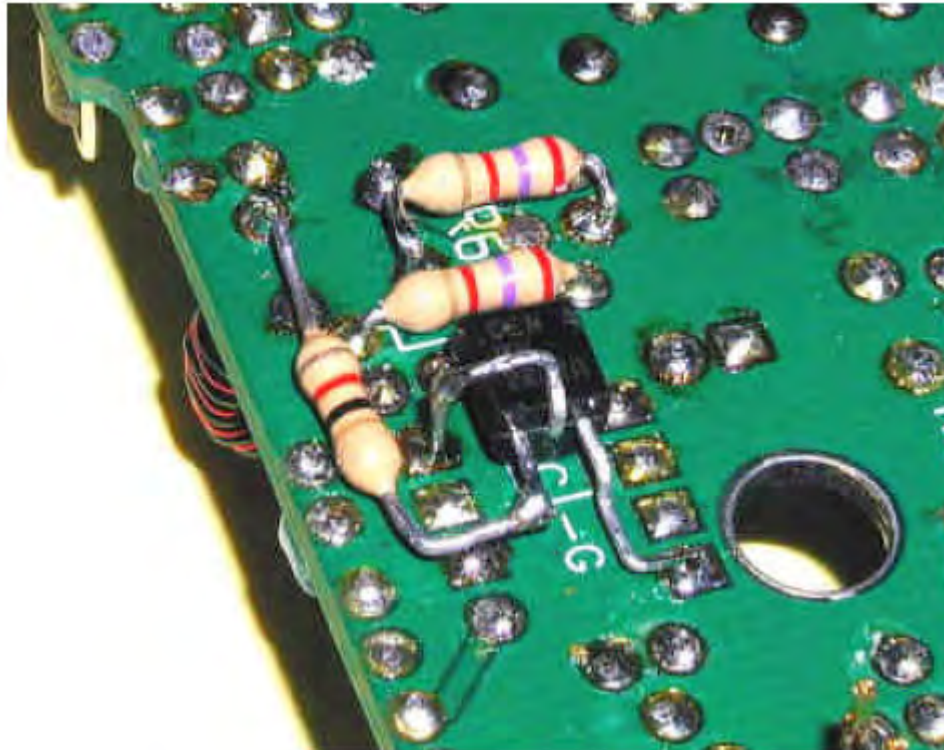

## MOD 2: Decreasing distortions

If the Level for the NE602 Input gets to high, this will cause AF clipping what means Intermodulations and Distortions of the AF signal.

To avoid this, we add a Resistor.

[ ] Check R2. If it is not 5k6 replace it with 5k6.

[ ] Solder 2k2 resistor between PIN 1 and PIN 2 of U5. This can easy be done if you use the input / output pins of Trimpot R1 (do not use the slider PIN)

## MOD3: Increasing the level of cmpression (first deccribed by DF7KHK QRP-Report, Magazin of German QRP Club DL-QRP-AG)

The SSM2165 can be used up to a compression of 15:1. Expierence with the German „Speaky“ transceiver say, that it makes sense to use compression up to 1:10 for QRP-SSB Transceivers.

The following mod is simple and allows to stay with the standard menu steps of K2 giving higher compression.

[ ] Remove RP5 on the SSB board.

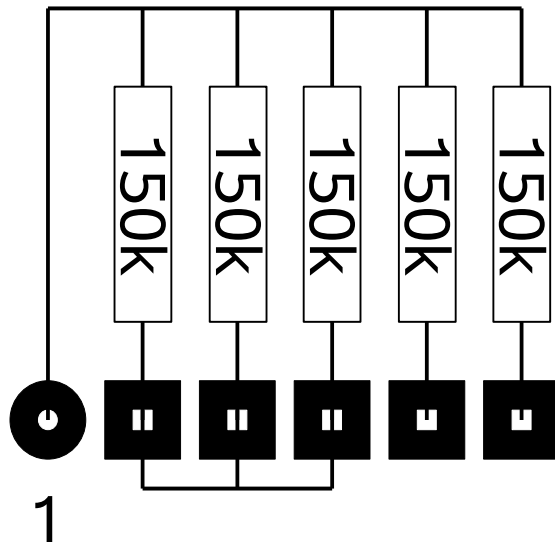

[ ] Install 5 150 k Resistors instead of the Resistor array, as shown in th edrawing. Connect PIN 2,3 and 4 on the solder side of the PCB.

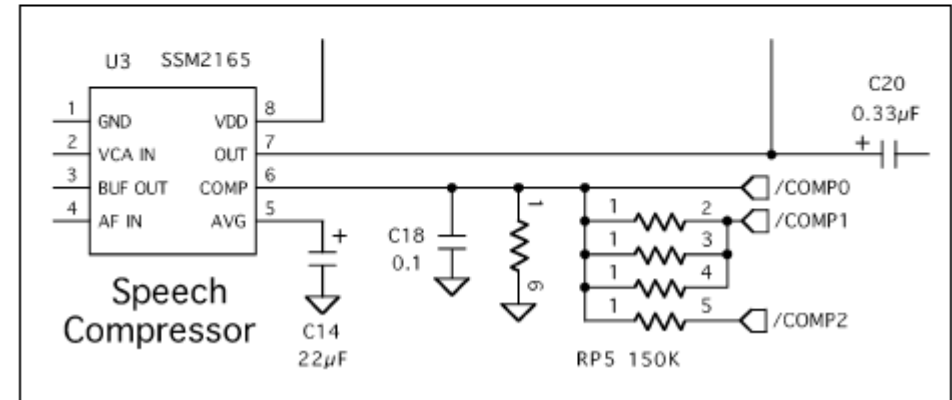
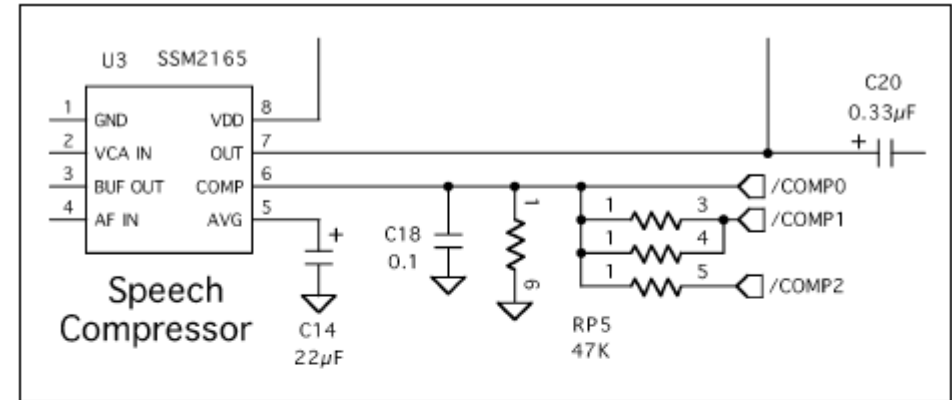

Upper drwaing: Original KSB2  
Lower Drawing: Modified KSB2

## Modifikation: Microphone Sensitivity (DF7KHK)

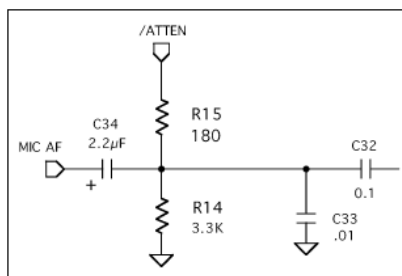
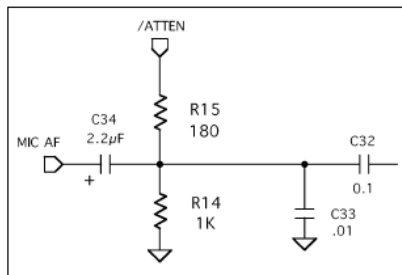

The K2 feeds the the compressor chip directly, not using any preamplifier. Regarding the KSB2 Manual the microphone should give 100mVpp (peak to peak) The Microphone signal is attenuated by R14/R15 using R15 in Menue settig SSBA=1 parallel to R14. If you increase the value of R14, you can use the microphon sensitivity. Using an MH2 Mike, we found 3,3 kOhm instead of the original 1k was the best value.

If you use other Microphones, you may play around with the values of R14/R15

### MOD: Optimizing (by DJ3FR)

This mods done now eventually generate so much power, that the ALC will not work properly. You will see more than normal RF output in thi case. If this happens with your 2, you must increase the values of R10 and R8 on the KSB2 board.

This can be done experimental, but you can get the right values also by a little measurement:

If you can measure the peak to peak Voltage at the Kathode of D14 during transmitting, this voltage can tranferred directly into a resistor value: for any 100mV you can substitute 100 Ohm. That means if you measure 300mV, R8 and R10 should be replaced by 300R Resistors. If you measure 500mV, you should replace them by 500R (use allways the nearest standard resistor value). You should measure

The next table shows what we hae measured at a couple of different KSB2 boards:

Meßpunkt	SSB unmodified	SSB modified
U3.4	30 mVpp	60 mVpp
U3.7	1,5 Vpp	1,2 Vpp
U5.1	600 mVpp	300 mVpp
U5.4	800 mVpp	1 Vpp
D14.K	100 mVpp	500 mVpp

### Alingnement:

**After this mods have been done, you must do the CAL FIL procedure.**

For all those of you who find the Noise Generator method to be good in CW but uncomfortable for SSB, I will decribe a simple alternative methode.

Connect your K2 to a Dummy load

Tune a control receiver to the K2 frequency, Use Head Phones

Set control RX to LSB

Set K2- SSB A Menue to 1 and SSBC Menue to 1-1 setzen.

Set Cal Fil Menue to OP1 Filter and the value of BFO frequency to the value recommended for OP1/LSB in KB2 manual page 10

Whistle into the microphone (PTT to send). Tune the frequency of the control receiver until you hear as exact as possible the same tone (like you do if you use the K2 SPOT function) If the RX signal is distorted, use RX Attenuation until you hear your whistle undistorted.

If both tones are equal, you are transceive. Now speak into the Mike and listen to the RX. If what you here is to low or to high in Frequency, go back to CAL FIL and change the frequency by 100Hz up or down. Tap Menue to leave CAL FIL and repeat. Repeat until you hear your voice „natural“ sound.

Repeate the complete procedure for USB (Don't forget to switch the RX to USB as well, use OP1 again)

K2 will use allways OP1 for transmit, so this procedure is not recommended

for the other SSB Bandwidth's which will be adjusted to best sound in receive mode only.

## Addition:

We found at a very low number of K2 (mostly K2/100) a small anomaly in the ALC funktion. Check the following and modify if necessary

Switch Display to ALC

Push PTT and talk your normal way. Look at the Bargraph, it should light the bars right to left. If MORE the 3-4 bars will flicker, you must do the following modification:

- [ ] Change R9 to 1.5K on the KSB2 board.
- [ ] Cut the PCB trace to the base of Q1,
- [ ] Solder a 1K resistor across the cut.